



NAVIA

TRAFFIC

Navia Traffic Installation manual

Contents

0 Document information	4
0.1 Abstract	4
0.2 Document status	4
0.3 List of applicable products	4
0.4 Revision history	4
1 Overview	5
2 Compatible Devices and Standalone Operation	7
3 Inventory of Materials	8
3.1 In the Box	8
3.2 Additional Required Equipment (Not Included)	8
4 Required Tools and Materials	8
4.1 Materials (Individual Components)	8
4.2 Available Connector Sets (Kits)	9
4.3 Tools	10
5 Mounting	11
6 Wiring and Electrical Connections	15
6.1 Wiring Harness Routing	15
6.2 Wire Preparation and Crimping	15
6.3 Pin Insertion and Extraction	16
6.4 Wire Splicing and Strain Relief	17
6.5 Power Supply	17
6.6 Data and Communication Ports	17
6.7 Wiring Recommendations	18
6.8 Audio	18
6.9 J200 Pinout	19
7 Integration with Navia Core Pro	21
8 Antenna Installation and Best Practices	22
8.1 FLARM Antenna Types and Specific Rules	22
8.2 General FLARM RF Antenna Placement Rules	23
8.3 Best Practices by Aircraft Type	24
8.4 The Advantage of RF Diversity (Two FLARM Antennas)	24
8.5 ADS-B and GPS Antennas	24
8.6 RF Cabling Extensions	24
8.7 Verifying Range and Temporary Mounting	24



9 System Configuration and Wi-Fi Portal	25
10 Software Updates	26
11 Maintenance and Service	26
12 System Status and Indicators	26
13 Post-Installation Checkout	27
14 Weight and Balance Data	27
15 Technical specification	28
16 Environmental data	29
17 Declaration of Conformity	30
18 Disclaimer and Legal Notice	31
19 Limited Warranty	32
20 End User License Agreement (EULA)	33
20.1 License and Limitation of Use	33
20.2 Terms of Use in Aviation	33
20.3 Data Privacy and Telemetry	33
20.4 Limitation of Liability	34
20.5 Indemnification	34
20.6 Governing Law and General Terms	34
21 Contact	35



Document information

0.1 Abstract

This document represents the installation manual for the Navia Traffic. The user manual, release notes, dataport and additional info can be found on www.lxnavigation.com.

0.2 Document status

Document status: PUBLIC

Document status	Explanation
Internal	Intended only for LX navigation staff
Public	Available publicly to all
Personal	Intended for a specific person and/or company, noted on this page
Dealer	Intended for a specific dealer, noted on this page
Manufacturer	Intended for a specific manufacturer, noted on this page

0.3 List of applicable products

Device	Part number	HW Version
Navia Traffic (Flarm only)	LX02000750	1.0
Navia Traffic (Dual Flarm and ADSB)	LX02000760	1.0

0.4 Revision history

Document name	Document revision	Date	Revised by	Approved by	Notes
N_TIM	R1	10.05.2025	B.D.	N.S.	initial release
N_TIM	R2	20.05.2026	N.S.	N.S.	Corrected J200 pinout: V_IN on pin 9, V_OUT on pins 1, 5, 17; updated Core Pro integration wiring table

Overview

Navia Traffic is the latest PowerFLARM OEM product designed and manufactured by LX navigation with full functionality and connectivity.

FLARM is the traffic awareness and collision avoidance technology with over 50,000 active aircraft. In Europe, essentially 100% of gliders have FLARM® and would never fly without it.

FLARM® works by calculating and broadcasting its own future flight path to nearby aircraft. At the same time, it receives the future flight path from surrounding aircraft. An intelligent motion prediction algorithm calculates a collision risk for each aircraft based on an integrated risk model. When a collision is imminent, the pilots are alerted with the relative position of the intruder, enabling them to avoid a collision.

Each FLARM® system determines its position and altitude with a sensitive GPS receiver. Based on speed, acceleration, track, turn radius, wind, altitude, vertical speed, aircraft type, and other parameters, a precise projected flight path can be calculated. The flight path, together with additional information such as a unique identification number, is encoded before being broadcast over an encrypted radio channel twice per second.

FLARM® is approved by EASA for fixed installation in certified aircraft. EASA supports FLARM® as it significantly decreases the risk of a mid-air collision between participating aircraft. FLARM® has been referenced in several EASA publications, including being approved as a Standard Change.

Navia Traffic features:

- Optional low-level IGC flight recorder (requires license)
- Optional ENL (Engine Noise Level) for piston gliders (requires license)
- Second FLARM® antenna (Diversity module)
- ADS-B in (With ADS-B collision warnings)
- External USB A port for data transfer
- WiFi® connectivity
- Bluetooth® connectivity
- FLARM Configurator WiFi Portal accessible with your smartphone for configuring your FLARM device and displayable data, export and import various files and connect with LX Cloud.



NOTE

IGC and ENL Licensing:

The Navia Traffic can function as an IGC flight recorder. However, please note that it operates as a **low-level logger** and does not contain internal hardware tamper switches or a security battery. The optional ENL sensor is suitable only for gliders equipped with standard piston engines. Both the IGC logging capability and ENL functionality require separate software license upgrades.



Compatible Devices and Standalone Operation

Navia Traffic is designed for ultimate flexibility. While it integrates seamlessly into the modern Navia avionics ecosystem (via the Navia Core Pro), it can also be utilized as a completely standalone FLARM device.

When operating in standalone mode, Navia Traffic outputs standard and advanced traffic data protocols over its independent RS232 communication ports. This makes the Navia Traffic universally compatible with almost any traffic display on the market.

LX Navigation Ecosystem

The device is natively compatible with the full range of legacy and modern LX navigation devices, including:

- LX Traffic Monitor 57 & LX Traffic Monitor 80
- LX Traffic Square
- LX Flarm LED Display Pro
- LX Flarm LED
- LX Flarm Color Display & LX Flarm Color Display II
- LX 10k
- LX Era
- LX Zeus
- LX Helios
- LX IRIS EFIS Pro

Third-Party Compatibility

Navia Traffic supports multiple industry-standard data protocols, which can be configured independently for each RS232 port via the Wi-Fi portal:

- **FLARM NMEA:** Compatible with any third-party display, moving map, or navigation system that can read standard Flarm NMEA data.
- **Garmin TIS:** RS232 ports can be configured to output Garmin TIS. This makes the device fully compatible with Garmin avionics, such as the G3X family and the Aera family of devices.
- **GDL90 Traffic:** The serial ports can also be configured to output the standard GDL90 Traffic protocol, supported by many popular EFB applications and third-party EFIS systems.

Inventory of Materials

Before beginning installation, please verify your materials against the lists below. Doing so ensures you have received all ordered parts from LX navigation in good condition. We advise keeping the original packaging for future storage or transport.

3.1 In the Box

- 1x Navia Traffic Unit
- 1x Device Registration Card (with QR code and portal link)
- 4x M2 Mounting screws

3.2 Additional Required Equipment (Not Included)

To fully install and utilize the Navia Traffic, the following components must be sourced separately depending on your specific aircraft setup.

- 1x GNSS Antenna (Part Number: **LX03000080** - 2J4301MPGFx-150RG174-C20NST)
- 2x FLARM "T" Dipole Antenna (Part Number: **LX03000030**)
- 1x ADS-B "T" Dipole Antenna (Part Number: **LX03000031**)

Note: For the physical installation, you will also need the mating connectors, appropriate pins, and aviation-grade wiring. A complete and detailed list of all required connector part numbers, pin types, and recommended wire gauges can be found in the "Required Tools and Materials" section.

Required Tools and Materials

To simplify ordering and assembly, LX navigation has created a comprehensive list of part numbers. You can purchase individual components like back shells, pins, and housings, or you can order complete **Connector Sets** that include everything needed for a specific device.

4.1 Materials (Individual Components)

The list below details the individual components required for the installation, including the LX navigation part number alongside the manufacturer's original description.

- 1x **LX04000310** – Receptacle for Female Contacts Housing D-Sub, High Density Connector 26 Position (164X11959X)
- 1x **LX04000260** – 15 Position Two Piece Backshell Connector 90°, 180° Shielded (16-001820)
- 26x **LX04000320** – HD D-Sub Contact Male Pin Gold 22 AWG Crimp Machined (162A18419X)
- Signal/power wire AWG 22 (M22759/16-22-9)

4.2 Available Connector Sets (Kits)

For your convenience, complete connector sets are available. Each set contains the exact quantities of housings, backshells, and pins required for the respective hardware interface.

Navia Traffic J200 connector set (LX02000940)

LX Part Number	Qty	Description
LX04000310	1	Receptacle for Female Contacts Housing D-Sub, High Density Connector 26 Position (164X11959X)
LX04000260	1	15 Position Two Piece Backshell Connector 90°, 180° Shielded (16-001820)
LX04000320	26	HD D-Sub Contact Male Pin Gold 22 AWG Crimp Machined (162A18419X)

GNSS Antenna (LX03000080)

LX Part Number	Qty	Description
LX03000080	1	GNSS antenna (2J4301MPGFx-150RG174-C20NST)

FLARM "T" Dipole Antenna (LX03000030)

LX Part Number	Qty	Description
LX03000030	2	FLARM "T" dipole antenna

ADS-B "T" Dipole Antenna (LX03000031)

LX Part Number	Qty	Description
LX03000031	1	ADS-B "T" dipole antenna

WARNING

Antenna Installation: All antennas (GNSS, FLARM, and ADS-B) must be installed on the exterior of the fuselage with a clear, unobstructed view of the sky.

Proper antenna placement is critical for:

- GNSS accuracy and continuous positional tracking (25 Hz updates)
- FLARM signal transmission and reception (traffic awareness)
- ADS-B performance (Mode-C transponder compatibility)

Improper antenna positioning will result in degraded GPS tracking, reduced FLARM range, and ADS-B reception issues. Mount antennas according to the installation diagram and ensure no obstruction from the airframe structure.



4.3 Tools

- PZ1 Screwdriver
- Pin crimping tool
- Pin insertion/extraction tool (e.g., M81969/1-01)
- **Non-magnetic tools** (e.g., beryllium, copper, or titanium)

Mounting

The dimensions of Navia Traffic are shown in the figure 1.

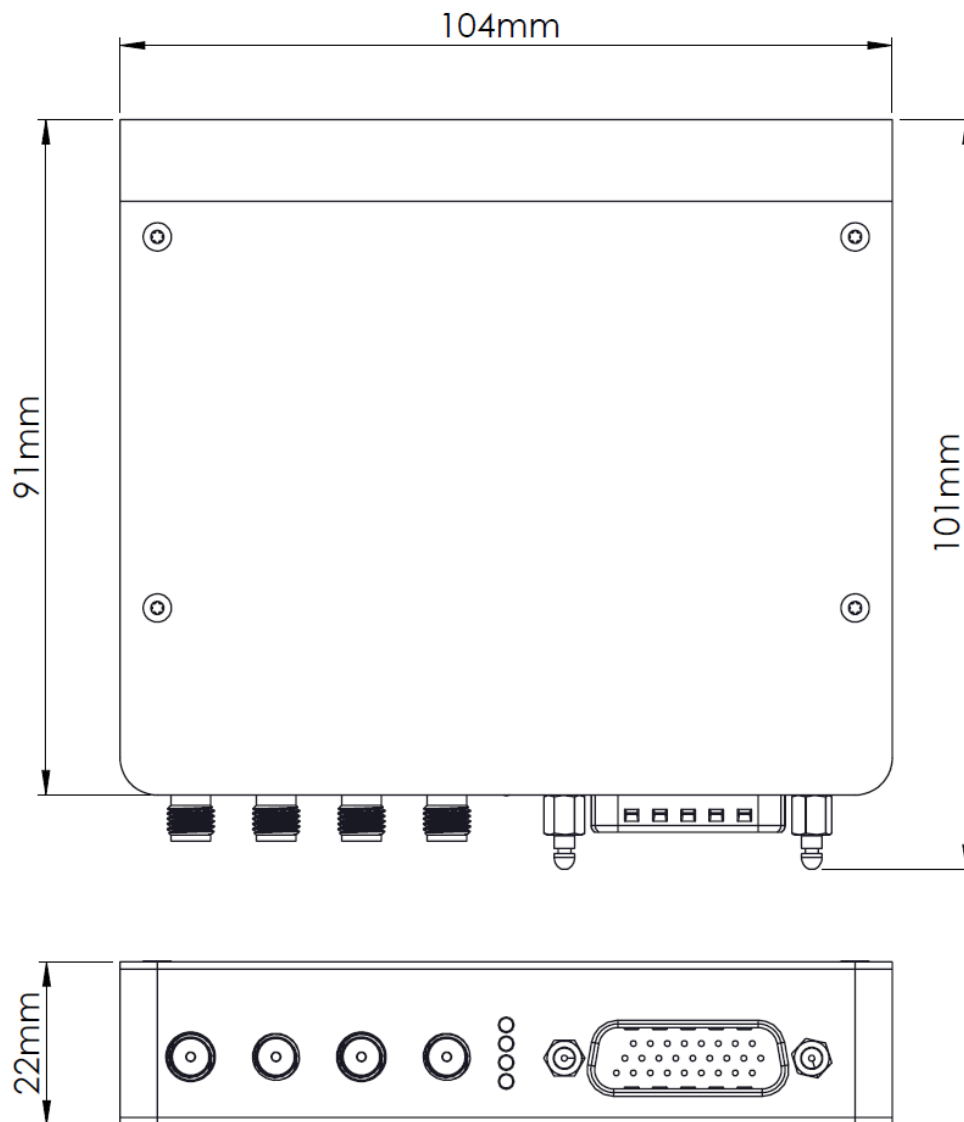

Figure 1. Device overview

Navia Traffic is designed with two M2 threaded holes on each side. The use of M2 DIN 7985 screws is recommended.

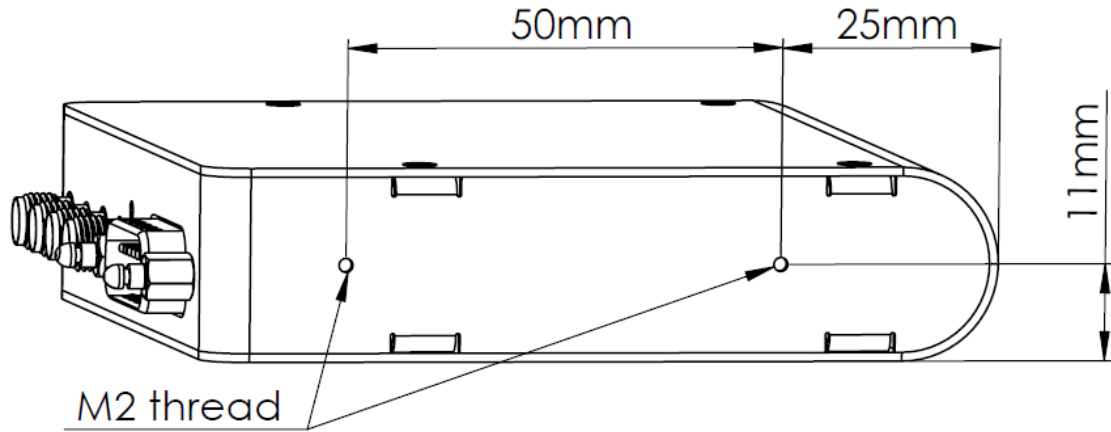

Figure 2. Mounting points

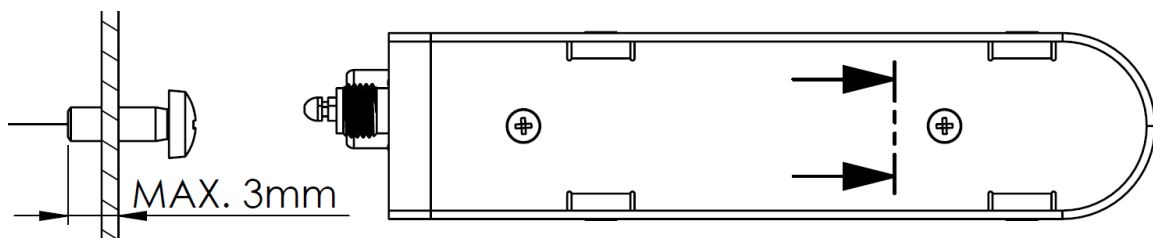

Figure 3. Length of screws

WARNING

Always use appropriate length of screws; using too long screws can damage internal components of Navia Traffic.

Navia Traffic is designed to be mounted in the avionics compartment or behind the instrument panel of the aircraft. Depending on the aircraft's individual requirements other locations may be suitable as well.

Navia Traffic does not require additional external cooling. Make sure that installation is performed behind the engine firewall.

Two mounting options are possible:

- mounting in a Navia mounting rack,
- on a flat surface using two mounting brackets.

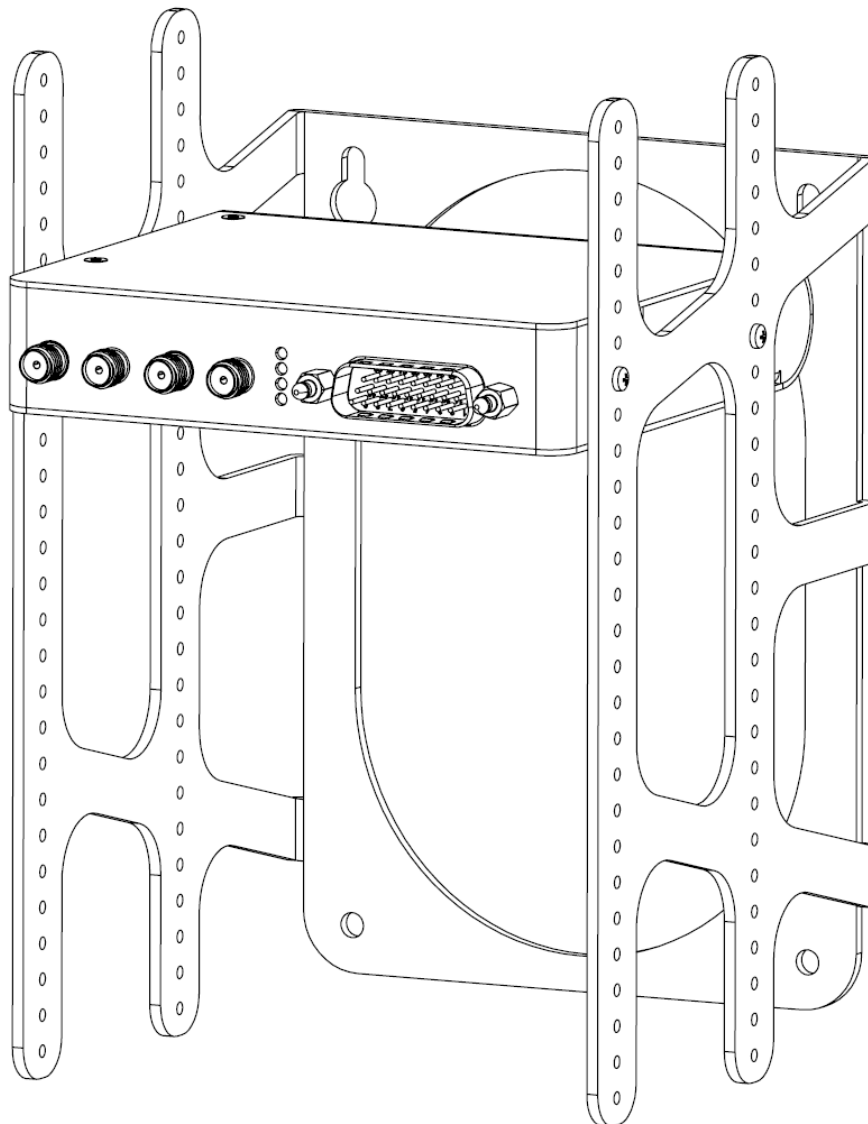

Figure 4. Mounting in Navia mounting rack

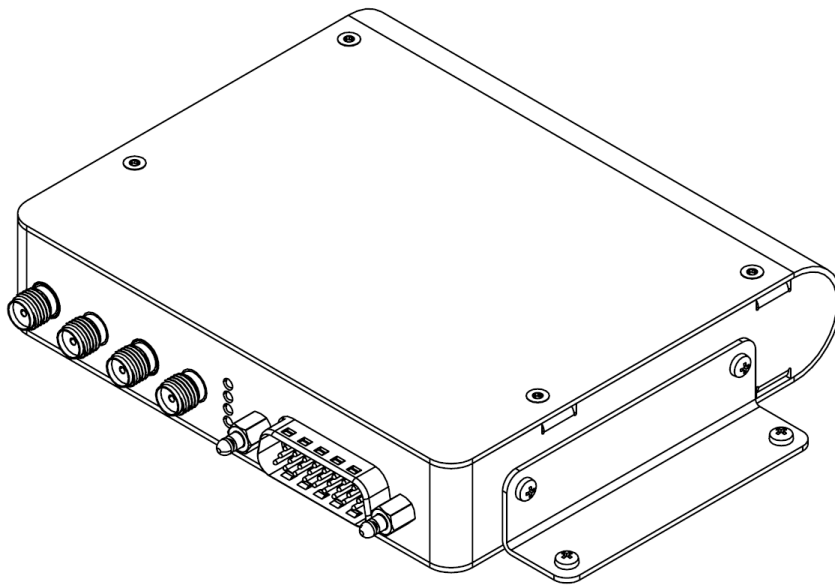

Figure 5. Mounting with two mounting brackets

WARNING

Compass Consideration:

Make sure that Navia Traffic is mounted **more than 25 cm** away from the aircraft's magnetic compass. When installation is completed, a fresh compass calibration is highly recommended (and in some certified installation cases, legally required).



Wiring and Electrical Connections

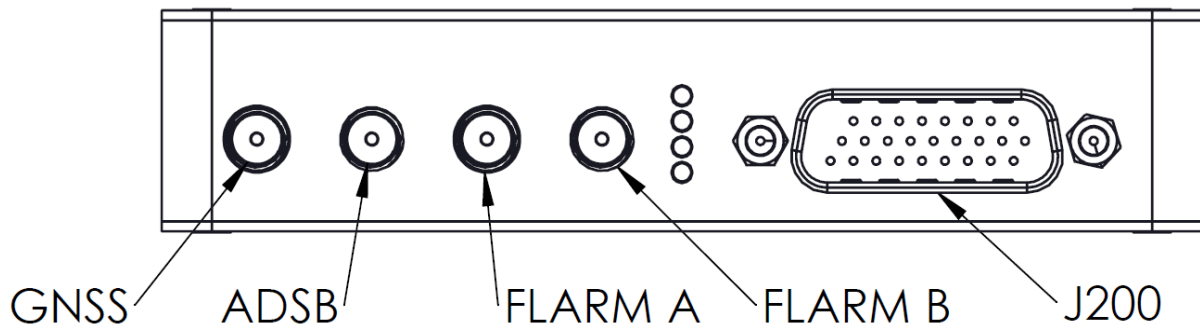

Figure 6. Front side connections

6.1 Wiring Harness Routing

When routing cables for the standalone Navia Traffic installation, follow these standard aviation precautions:

- All cable routing should be kept as short and as direct as possible.
- Check there is ample space for the cabling and mating connectors.
- Avoid sharp bends in cabling.
- **Moisture Prevention:** Form a "drip loop" (a slight downward U-shape) in the harness just before the wire bundle enters the device connector. This prevents moisture or condensation from running down the wires directly into the pins and connector housing.
- Avoid routing cables near heat sources, RF sources, EMI interference sources, or near power for fluorescent lighting.
- Route the GPS and FLARM antenna cables as far as possible away from all COM transceivers and antenna cables.

WARNING

CAUTION: Electro-Static Discharge (ESD)

To avoid damage to the Navia Traffic, take precautions to prevent Electro-Static Discharge (ESD) when handling connectors and associated wiring. ESD damage can be prevented by touching an object that is of the same electrical potential as the device before handling the device itself.

6.2 Wire Preparation and Crimping

Wire Stripping

Carefully strip approximately 3 to 4 mm of insulation from the end of the wire. Ensure that you use a properly sized wire stripper so that no underlying copper strands are nicked, cut,



or broken during the process. Damaged strands significantly reduce the current-carrying capacity and mechanical strength of the wire.

Crimping Process and Inspection

It is mandatory that all pins are **crimped and not soldered**. Soldering creates a rigid point on the wire that is highly susceptible to breakage from aircraft vibration. After crimping, inspect the connection to verify a good crimp: the bare copper strands should be visible in the pin's inspection hole, and the wire insulation must not be caught inside the wire crimp barrel. Perform a gentle "pull test" to ensure the wire is securely held. Once verified, simply push the pin into the corresponding hole in the connector housing until you feel it lock into place.

6.3 Pin Insertion and Extraction

Navia Traffic utilizes a 26-pin High-Density D-Sub connector (J200), which uses smaller pins (Size 22) than standard D-Sub connectors. It is crucial to use the correct dedicated tool to avoid damaging the delicate locking tabs inside the connector housing:

- **M81969/1-01 (Green/White):** Use this tool for inserting and extracting the High-Density pins (Size 22) and AWG 22 wire used on the Navia Traffic connector.

How to Insert a Pin:

1. Place the crimped wire into the groove of the green insertion tip so the tip rests against the shoulder of the crimped pin.
2. Carefully align the pin with the rear of the desired cavity on the connector housing.
3. Push straight in until you feel and hear a positive "click," indicating the internal retaining clip has locked the pin in place.
4. Pull the tool straight back to remove it, and perform a gentle pull-test on the wire to verify it is securely locked.

How to Extract a Pin:

1. Slide the white extraction tip of the tool over the wire of the pin you wish to remove.
2. Push the white tip straight into the rear of the connector housing cavity. Apply firm, steady forward pressure until the tool bottoms out; this action safely expands the internal metal locking tabs.
3. While keeping the tool fully seated, pinch the wire against the tool and pull both the tool and the wire out together simultaneously. *Warning: Never forcefully yank the wire without the extraction tool properly seated, as this will permanently destroy the connector's internal locking mechanism.*

6.4 Wire Splicing and Strain Relief

WARNING

Wire Splicing Warning:

In scenarios where splicing is absolutely unavoidable, it must be done correctly using avionics-grade environmental splices (such as proper crimp butt-splices covered with dual-wall adhesive heat shrink or dedicated solder sleeves). Never use standard electrical tape, bare twists, or twist-on wire connectors inside an aircraft.

Strain Relief

Once the connector is fully populated, tightly secure the exiting wire bundle using zip ties or aviation lacing cord to the connector backshell. Proper strain relief prevents the weight and vibration of the wire bundle from transferring mechanical stress directly to the individual pins, ensuring long-term reliability.

6.5 Power Supply

Navia Traffic requires a DC power input in the range of **9 to 32 V DC**. Power is supplied via the 26-pin high-density D-Sub connector (J200). The main power input is on `V_IN` (pin 9), with dedicated ground return on `GND` (pins 2, 6, 10, 16, 18). Pins 1, 5, and 17 are `V_OUT` outputs intended for powering a connected display.

It is recommended to use an external fuse or circuit breaker, as the device does not include internal overcurrent protection. A manually resettable circuit breaker rated at **3 A** is strongly advised. These breakers enable individual system protection without affecting the main avionics power bus.

Before applying power, ensure that wiring is properly secured and insulated, and that there are no short circuits. Once the connector is plugged into the device and the main power supply is present, the unit will power on automatically.

6.6 Data and Communication Ports

Navia Traffic supports communication over three independent RS232 ports via the same J200 connector:

- **RS232_1:** TX (pin 3), RX (pin 4) – Full two-way communication.
- **RS232_2:** TX (pin 7), RX (pin 8) – Full two-way communication.
- **RS232_3:** TX (pin 15), RX (pin 14) – Full two-way communication.

These interfaces conform to RS-232C (EIA standard) levels, providing at least ± 5 V swing when driving a standard RS-232 load.

It is critical that a direct ground connection (`GND`) is made between Navia Traffic and other connected RS232 devices (like third-party displays). Connecting only through airframe ground is insufficient. Multiple ground pins are available for this purpose (e.g., pins 2, 6, 10, 16, 18).

6.7 Wiring Recommendations

While generic wiring can be used, it is strongly recommended to use a shielded cable with twisted pairs for long runs. This improves noise immunity and reduces potential for communication errors. One twisted pair should be used for each TX/RX pair, and another pair for V_IN (pin 9) and GND.

6.8 Audio

Navia Traffic provides a differential audio output via the J200 connector for use with onboard audio systems, intercoms, or external speakers. The audio signal is available on:

- **AUDIO_POS (pin 11)** – Positive audio output
- **AUDIO_NEG (pin 12)** – Negative audio output

This differential amplified power output is designed to run a speaker (minimal 4 Ohm resistance). Audio output is 3.2W at 4 Ohm.

<p style="text-align: center;">WARNING</p> <p style="text-align: center;">Important Audio Grounding:</p> <p style="text-align: center;">AUDIO_POS and AUDIO_NEG must be connected as a pair. Do not connect either line to ground. Doing so may damage the internal audio circuitry or degrade performance.</p>
--

Ensure that the receiving audio system accepts differential input without common ground (GND). If connecting to an unbalanced (single-ended) system, use a suitable audio transformer or differential-to-single-ended converter.

6.9 J200 Pinout

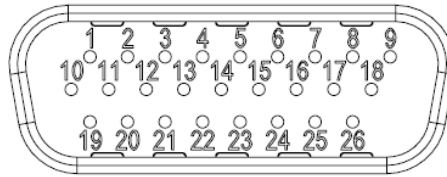

Figure 7. J200, as viewed looking at connector on unit

Pin	Name	Description
1	V_OUT	Power Out For Display
2	GND	Power / Signal Ground
3	RS232_1_TX	RS232 Port 1 Transmit
4	RS232_1_RX	RS232 Port 1 Receive
5	V_OUT	Power Out For Display
6	GND	Power / Signal Ground
7	RS232_2_TX	RS232 Port 2 Transmit
8	RS232_2_RX	RS232 Port 2 Receive
9	V_IN	Main Power Input (9-32V DC)
10	GND	Power / Signal Ground
11	AUDIO_POS	Audio Output +
12	AUDIO_NEG	Audio Output -
13	PWR_EN	Power Enable
14	RS232_3_RX	RS232 Port 3 Receive
15	RS232_3_TX	RS232 Port 3 Transmit
16	GND	Power / Signal Ground
17	V_OUT	Power Out For Display
18	GND	Main Power Ground
19	RELAY_OUT	Relay Output
20	RELAY_IN	Relay Input
21	DIN_1	Digital Input 1
22	DIN_2	Digital Input 2
23	VCC_3_3V	Logic Power Output
24	USB_5V	USB Power
25	USB_N	USB Data -
26	USB_P	USB Data +



WARNING

Double-check pinout connections before applying power. Incorrect wiring can permanently damage the device or connected equipment.



Integration with Navia Core Pro

The most optimal integration for the Navia Traffic is within the modern Navia avionics ecosystem, connecting directly to the Navia Core Pro. The Navia Traffic is specifically designed to be physically installed inside the Navia Rack system, directly on top of the Navia Core Pro, perfectly complementing the entire avionics suite.

The basic electrical connection requires only 4 wires (Power, Ground, and two RS232 data lines) between the units.

Data and Power Wiring

We recommend using **RS232 5** on the Navia Core Pro for data communication and **POWER_OUT3** to provide continuous power to the traffic unit whenever the avionics are powered on. On the Navia Traffic side, use the **RS232_1** port (Pins 3 and 4) and the primary **V_IN** and **GND** (Pins 9 and 18) on the J200 connector.

Navia Core Pro (J101 Connector)	Navia Traffic (J200 Connector)
POWER_OUT3 (Pin 6)	V_IN (Pin 9)
GND (Pin 19)	GND (Pin 18)
RS232_RX5 (Pin 11)	RS232_1_TX (Pin 3)
RS232_TX5 (Pin 23)	RS232_1_RX (Pin 4)

NOTE

When integrated with the Navia Core Pro, the audio output from the Navia Traffic does not need to be wired separately to your intercom. The Navia Core Pro receives the digital traffic data via RS232 and uses its own advanced internal DSP to generate and route Spatial Audio alerts directly to your connected speakers or headsets.



Antenna Installation and Best Practices

Navia Traffic requires proper antenna installation for correct system operation. **No antennas are provided** with the Navia Traffic unit and must be sourced separately.

WARNING

Crucial Note on RF Performance:

It is highly important to understand that all modern FLARM devices across the aviation market utilize the exact same core RF technology and modules manufactured by FLARM Technology Ltd. Consequently, the inherent RF transmission and reception capabilities of the Navia Traffic are completely identical to any other certified FLARM unit.

When users experience poor traffic reception, blind spots, or limited range, it is almost exclusively the result of improper antenna placement, incorrect orientation, or poor cable routing, and **not** a fault of the Navia Traffic device itself. Please follow the strict guidelines below to ensure optimal performance.

WARNING

Correct Port & Transmitter Damage:

It is absolutely critical to connect the correct type of antenna to its corresponding port as labeled on the device chassis. Powering on the Navia Traffic and allowing its internal modems to transmit without an antenna securely connected can cause permanent damage to the internal RF transmitters.

WARNING

Connector Torque (Hand-Tighten Only):

Do not use tools to tighten any SMA connectors. They should simply be tightened firmly by hand. If tools are used, there is a high chance of over-tightening the connection. When attempting to remove an over-tightened connector later, the excessive torque can cause the internal SMA receptacle to loosen and spin within the chassis. This will twist and permanently break the delicate internal coaxial cable.

8.1 FLARM Antenna Types and Specific Rules

LX navigation provides different types of antennas (sold separately) to suit various aircraft types. It is crucial to understand the differences and installation requirements for each type:

1. T-Shaped Antennas (Center-Fed Dipoles)

These are the standard antennas often utilized in fiberglass gliders.

- **Ground Plane:** These antennas do **not** require a ground plane to operate.



- **Conductive Materials:** They are highly sensitive to their surroundings. Never mount them directly against or touching any conductive material (e.g., any type of metal or carbon fiber). Ensure the antenna tips are entirely clear of conductive structures.
- **Cable Routing (Critical):** The coaxial cable **must** be guided horizontally away from the center of the T-shape. **Do not** route or tie the cable parallel to either vertical arm of the dipole. Doing so will severely distort the radiation pattern and ruin your transmission range.
- **Canopy Clearance (ESD):** The human body, as well as friction from fabric canopy covers on plastic canopies, can amass high electrostatic voltages. Make sure all parts of the antenna have at least 2 cm of clearance from the canopy to prevent ESD damage.

2. Standard Whip Antennas (Monopoles)

These are simple 1/4 wave antennas, often used on top of glare shields.

- **Ground Plane Required:** Unlike dipoles, monopole antennas **require** a metallic ground plane of at least 80 mm (approx. 3 inches) radius perpendicular to the antenna base to function correctly.
- **Blind Spots:** Be aware that monopoles naturally generate a blind spot directly below the ground plane.

3. External Antennas (e.g., AV-75)

These are rugged, aerodynamic antennas designed for external mounting on light aircraft and helicopters.

- The aircraft's metal skin acts as the required ground plane for these antennas. They offer the highest performance for powered aircraft when properly separated (top and bottom).

8.2 General FLARM RF Antenna Placement Rules

Regardless of the antenna type chosen, the following rules apply universally:

- **Orientation (Vertical Polarization):** FLARM uses a vertically-polarized radio signal. You **must not** tilt the antennas more than $\pm 15^\circ$ from the vertical. A horizontally mounted antenna (tilted 90°) will receive almost nothing and have near-zero range.
- **Human Attenuation:** Keep in mind that the human body strongly attenuates RF signals. Ensure the antennas have a clear line of sight outside the aircraft that is not completely blocked by the pilot or passengers.
- **Antenna Separation:** Antennas must be physically separated to prevent interference:
 - Min. distance between FLARM 1 and FLARM 2 antennas: **30 cm (1 ft)**
 - Min. distance between any FLARM antenna and the GPS antenna: **30 cm (1 ft)**
 - Min. distance between the ADS-B antenna and the GPS antenna: **10 cm (4 inches)**
- **No Splitters:** Never use a passive RF splitter to attach two antennas to one port. This will cause destructive interference and highly unpredictable range. Use the dedicated FLARM 1 and FLARM 2 ports for true RF diversity.
- **Directional Antennas:** The use of directional antennas is highly discouraged as they will severely degrade range in other directions. Stick to high-quality omnidirectional antennas.

8.3 Best Practices by Aircraft Type

The radiation pattern and range are heavily influenced by the materials used in your aircraft's construction.

- **Fiberglass and Kevlar Gliders:** These materials barely attenuate RF signals. Internal antennas (such as T-shaped center-fed dipoles) work exceptionally well when mounted inside the fuselage or vertical stabilizer. Ensure they do not touch any conductive materials (e.g., control rods, wiring bundles).
- **Carbon Fiber and Metal Airplanes:** RF signals **cannot** penetrate metal or carbon fiber. For these aircraft, you must either mount antennas externally (e.g., using AV-75 external antennas) or position internal antennas near a non-conductive window or canopy with an absolutely unobstructed view.

8.4 The Advantage of RF Diversity (Two FLARM Antennas)

The Navia Traffic features a secondary FLARM antenna port (FLARM 2) which enables true RF Diversity. While a single antenna (FLARM 1) can provide adequate coverage in a clean, non-conductive environment, aircraft structures inevitably create "blind spots" where the signal is blocked.

By installing a second FLARM antenna, the Navia Traffic can simultaneously transmit and receive from both ports. For metal or carbon fiber airplanes, the standard and most effective configuration is to mount **one external antenna on the top** of the fuselage and **one external antenna on the bottom**. This guarantees uninterrupted 360-degree spherical coverage, preventing your own airframe from shadowing the signal during steep banks, climbs, or descents.

8.5 ADS-B and GPS Antennas

- **ADS-B Antenna:** The ADS-B port requires a dedicated 1090 MHz antenna for receiving ADS-B traffic and collision warnings. While placement is slightly less critical than FLARM (due to the much stronger ADS-B signal), standard clearance and vertical orientation rules still apply.
- **GPS Antenna:** Connect the GPS receiver antenna to the SMA connector marked GPS. Install it horizontally with the "GPS" sign pointing to the sky. It must have a clear "sight" to the satellites and should not be installed under metal or carbon fiber instrument panels.

8.6 RF Cabling Extensions

If your installation requires placing the antennas further away from the Navia Traffic unit, you may use extension cables. However, you must use high-quality 50 Ω coaxial cable (such as RG58, RG142B, or RG400). **Do not** use poor-quality cables like RG174.

The total signal attenuation of the extension cable should remain **below 1.5 dB**. Keep in mind that every additional connector or adapter introduced into the line will cause further signal loss.

8.7 Verifying Range and Temporary Mounting

Because every aircraft's material composition is different, we highly recommend starting with a **temporary antenna installation** (e.g., using heavy-duty double-sided tape and a folded cardboard stand painted black to avoid canopy reflections).



Before making the installation permanent, fly with the temporary setup and evaluate the performance using official FLARM diagnostic tools:

- **FLARM Online Range Analyzer:** Upload your recorded IGC flight logs to flarm.com/support/tools-software/flarm-range-analyzer/ to evaluate the 3D receive range of your antennas. (Requires flights with abundant traffic).
- **KTRAX Live Range Analyzer:** Use ktrax.kisstech.ch/flarm-liverange/ to check how well the Open Glider Network (OGN) ground stations are receiving your transmitted signal.

NOTE

Route the wiring bundle as appropriate. Avoid sharp bends. Secure all wires to minimize vibration damage. Do not route cables near high voltage sources or alongside Radio and Transponder antennas.

System Configuration and Wi-Fi Portal

Navia Traffic generates its own local Wi-Fi network, allowing for wireless configuration, data transfer, and diagnostics using any smartphone, tablet, or laptop.

NOTE

Always-On Wi-Fi:

Unlike the Navia Sense (which disables its standalone Wi-Fi when connected to the Navia Core Pro), the Navia Traffic's Wi-Fi Access Point remains **fully active and accessible at all times**, even when it is integrated and communicating with the Navia Core Pro. This allows pilots to connect their personal devices to the FLARM portal during flight without disrupting the main avionics data flow.

1. Power on the Navia Traffic unit.
2. Open the Wi-Fi settings on your mobile device or computer and connect to the network named **Navia Traffic xxxxx** (where xxxxx is your device's unique serial number).
3. The password for your specific device is located on the included Device Registration Card.
4. Open a web browser and navigate to **192.168.4.1** to access the FLARM Configurator WiFi Portal.

From this portal, you can:

- Configure your aircraft details (Hex ID, aircraft type).
- Adjust RS232 baud rates and data protocols for connected displays.
- Export IGC flight logs and import flight declarations.
- Connect the device to LX Cloud.

Software Updates

Keeping your FLARM firmware up to date is mandatory for the system to continue broadcasting and receiving traffic data. The FLARM protocol undergoes periodic mandatory updates.

To update Navia Traffic via Wi-Fi:

1. Download the latest FLARM firmware update file to your smartphone or laptop.
2. Connect to the Navia Traffic Wi-Fi portal (**192.168.4.1**).
3. Navigate to the **Software Update** section, upload the firmware file, and initiate the update. Do not disconnect power during the update process.

Maintenance and Service

The Navia Traffic is a solid-state device requiring no regular internal maintenance by the pilot or installer.

5-Year Recalibration (IGC Models)

If your Navia Traffic is equipped with the IGC flight recorder license, there is still a mandatory calibration interval of **5 years**. Because the device does not use an internal security battery or electronic tamper switches, this recalibration must be performed in a **traditional barochamber**. Every 5 years, the unit must be returned to LX navigation or an authorized partner for this standard barocalibration to maintain its low-level IGC approval status.

WARNING

DO NOT OPEN THE DEVICE: There are **no user-serviceable parts** inside the Navia Traffic. If your device requires repairs, it must be removed from the aircraft and sent directly to LX navigation or to a certified, authorized partner for service.

System Status and Indicators

The Navia Traffic features 4 status LEDs on its front panel to provide immediate visual confirmation of the system's operational state. From bottom to top, these indicators represent:

- **PWR (Power - Bottom LED):** Illuminates to confirm the device is receiving adequate power and is turned on.
- **GPS:** Illuminates when the internal GPS receiver has acquired a valid 3D satellite fix.
- **RX (Receive):** Flashes or illuminates to indicate that the device is actively receiving FLARM or ADS-B RF signals from surrounding traffic.
- **TX (Transmit):** Flashes or illuminates to indicate that the device is actively transmitting your aircraft's projected flight path via RF to surrounding traffic.



Post-Installation Checkout

NOTE

After finishing the installation, check that the device is fully operational before closing the instrument panel cover.

1. **Power On:** Apply aircraft power and ensure the connected traffic displays turn on and receive data.
2. **GPS Fix:** Move the aircraft out of the hangar so the GPS antenna has a clear view of the sky. Connect to the Wi-Fi portal and check the status page to verify a valid 3D GPS fix.
3. **Data Output:** If connected to a 3rd party display via RS232, verify the display is receiving valid NMEA/FLARM data strings without error messages.
4. **Audio Test:** If the differential audio is connected to the aircraft intercom, configure a test alert via the Wi-Fi portal to verify audio volume and clarity.

NOTE

If you run into any issues, contact us at info@lxnavigation.com for assistance.

Weight and Balance Data

After installing the Navia Traffic, it is a strict regulatory requirement that the aircraft's Weight and Balance records be updated to reflect the new equipment list.

To assist your mechanic or installer, LX navigation provides a dedicated **Equipment Datasheet** that contains the exact mass and center-of-gravity (CG) moment/arm data for all devices in the Navia system. Ensure the new empty weight and CG are physically calculated and logged in the aircraft's official records before flight.

Technical specification

Description	Unit	Value
Dimensions	[mm]	22 x 104 x 101
Power supply	[V DC]	9.0 - 32.0
Nominal Voltage	[V DC]	13.8
Average Power Consumption	[W]	2.35
Mass	[g]	153
Ground Survival Temperature	[°C]	-55 - +85
Operating Temperature	[°C]	-20 - +55
Relative Humidity	[%]	0 - 98
Max. Operational Altitude	[ft]	45,000
Operational Shock		10 g
Crash Safety Shock		20 g
Vibration		DO-160D U F/F1

NOTE

This specification applies to all variants of Navia Traffic

Environmental data

Description	Section	Category	Conditions
Temperature / Altitude	4.0	D1	
Low Ground Survival Temperature	4.5.1	D1	-55 °C
Low Operating Temperature	4.5.1	D1	-40 °C
High Ground Survival Temperature	4.5.2	D1	+85 °C
High Short Time Operating Temperature	4.5.2	D1	+70 °C
High Operating Temperature	4.5.3	D1	+55 °C
In Flight Loss of Cooling	4.5.4	Z	No auxiliary cooling required
Altitude	4.6.1	D1	45,000 ft
Temperature Variation	5.0	B	
Humidity	6.0	A	
Shock	7.0	B	
Vibration	8.0	U/U2	Vibration curve F/F1 (robust vibration, helicopter)
Explosion Proofness	9.0	X	not tested
Water Proofness	10.0	X	not tested
Fluids Susceptibilities	11.0	X	not tested
Sand and Dust	12.0	X	not tested
Fungus Resistance	13.0	X	not tested
Salt Spray	14.0	X	not tested
Magnetic Effect	15.0	Z	less than 0.3m
Power Input (DC)	16.0	B	
Voltage Spike Conducted	17.0	B	
Audio Frequency Conducted Susceptibility	18.0	B	
Induced Signal Susceptibility	19.0	X	not tested
Radio Frequency Susceptibility	20.0	T	Radiated Susceptibility T
Conducted Susceptibility Emission of RF	21.0	M	Except intended operating frequencies (868/915 MHz 6 and 2.4/5 GHz)
Lightning Induced Transient Susceptibility	22.0	A2XXX	
Lightning Direct Effects	23.0	X	not tested
Icing	24.0	X	not tested
Electrostatic Discharge (ESD)	25.0	A	
Fire, Flammability	26.0	X	enclosure made of aluminum (Al) sheet

Environmental tests are performed in accordance with RTCA DO-160.



Declaration of Conformity

Identification of product

Product Name: Navia Traffic (Flarm only), Navia Traffic (dual Flarm and ADSB)S

Part Number(s): LX02000750, LX02000760

Manufacturer

LX navigation d.o.o., Tkalska ulica 10, SI-3000 Celje, Slovenia

Related Directives

LX navigation d.o.o. declares under our sole responsibility that the product complies with the essential requirements of the following European Directives and therefore bears the **CE marking**:

- **2014/53/EU** Radio Equipment Directive (RED)
- **2015/863/EU** Restriction of Hazardous Substances (RoHS 3)

Harmonized Standards Applied

The following harmonized standards have been applied to demonstrate conformity:

- **Health & Safety (Article 3.1a):** EN 62368-1:2014+A11:2017 (Product Safety), EN 62311:2008 (RF Exposure)
- **Electromagnetic Compatibility / EMC (Article 3.1b):** EN 301 489-1 V2.2.3, EN 301 489-3 V2.1.1, EN 301 489-17 V3.2.4, EN 301 489-19 V2.1.1
- **Radio Spectrum Efficiency (Article 3.2):** EN 300 328 V2.2.2, EN 301 413 V1.1.1, EN 300 220-1 V3.1.1, EN 300 220-2 V3.1.1
- **Additional Compliance:** EN 63000:2018 (RoHS)

Aviation Environmental Testing

While this device does not hold a formal aviation certification (such as an ETSO/TSO), it has been rigorously tested to meet the demanding environmental conditions for airborne equipment outlined in **RTCA DO-160**.

Signed for and on behalf of LX navigation d.o.o.

Name / Title: Nik Šalej, CEO

Date: March 20, 2026

Location: Celje, Slovenia



Disclaimer and Legal Notice

Accuracy of Information

While every effort has been made to ensure that the information contained in this manual is accurate and complete, LX navigation d.o.o. assumes no responsibility or liability for any errors, omissions, or inaccuracies. The information in this document is provided "as is" and is subject to change without prior notice. LX navigation reserves the right to continually improve its products, software, and documentation without obligation to notify any person or organization of such revisions or changes.

Operational Responsibility

The Navia avionics system is designed to provide supplementary flight data and enhanced situational awareness. It is **not** a certified primary flight instrument and must not be used as the sole means of navigation, collision avoidance, or instrument flight (IMC/IFR). The pilot in command is solely responsible for the safe operation of the aircraft, adherence to all applicable aviation regulations, and the proactive separation from other aircraft, terrain, and obstacles.

Limited Warranty

Two-Year Hardware Warranty

LX navigation warrants this hardware product to be free from defects in materials and workmanship under normal aviation use for a period of **two (2) years** from the date of original retail purchase.

During this warranty period, if a defect arises, LX navigation will, at its sole discretion and to the extent permitted by law, either:

1. Repair the product at no charge using new or refurbished replacement parts.
2. Exchange the product with a new or refurbished product that is functionally equivalent to the original.

Warranty Exclusions

This Limited Warranty does not apply to any software (including the operating system and internal firmware), databases, or any third-party equipment. Furthermore, this warranty does not cover damage caused by:

- Misuse, abuse, accidents, or neglect (including physical impact or water damage).
- Unauthorized modifications, alterations, or repairs performed by anyone other than LX navigation or an officially certified service partner.
- Opening the device enclosure or breaking the factory security seals.
- Improper installation, wiring, or application of incorrect voltage.
- Environmental damage extending beyond the certified limits of the device, including concentrated solar heat damage ("sunburns") on LCD screens.

To obtain warranty service, the customer must contact LX navigation support. Shipping costs to the LX navigation repair facility are the responsibility of the customer.



End User License Agreement (EULA)

By purchasing, installing, or using any Navia device, or by downloading, accessing, or using any LX navigation software, firmware, license key, or data, you agree to the following terms and conditions. If you do not agree with these terms, do not install or use the device, software, or data.

20.1 License and Limitation of Use

1.1. License. Subject to the terms of this Agreement, LX navigation hereby grants you a non-exclusive, non-transferable right to use the software, firmware, license keys, and data embedded in binary executable form solely for your own personal or internal flight operations. You acknowledge that all software, algorithms, and related data are proprietary intellectual property of LX navigation and its suppliers.

1.2. Limitation. Software, firmware, and license keys may only be used as embedded in devices manufactured by LX navigation. No other licenses are granted by implication or otherwise. You may not reverse engineer, decompile, disassemble, or manipulate the software or hardware in any way.

20.2 Terms of Use in Aviation

2.1. Installation. The device must be installed according to the official LX navigation Installation Instructions and must comply with the applicable national aviation regulations (e.g., EASA Standard Change or Minor Change). Installation must be verified by certified maintenance staff where required by law.

2.2. Safety Limitations. The Navia system cannot warn or provide data in all situations. Sensors may be degraded by GPS outages, poor antenna placement, or environmental factors. The system does not issue resolution advisories. It is the sole responsibility of the pilot in command to decide upon the use of the system and to maintain safe flight conduct.

2.3. Mandatory Updates. System firmware and applicable databases (e.g., Obstacles, Airspace) must be updated regularly. LX navigation reserves the right to render outdated firmware versions inoperable to ensure network compatibility and system safety.

20.3 Data Privacy and Telemetry

3.1. Data Collection. Navia devices may collect, store, and transmit flight data, including aircraft identification, GPS position, altitude, and system diagnostics. LX navigation may use this data for system improvement, troubleshooting, and Search and Rescue (SAR) purposes.



3.2. Data Sharing. LX navigation is not responsible for any third-party device, software, application, or network that receives, intercepts, stores, or broadcasts data transmitted by your Navia device.

20.4 Limitation of Liability

4.1. "As Is" Provision. While the hardware is covered by a 2-year warranty, all software, firmware, databases, and digital services are provided on an "as is" and "as available" basis without any implied warranties of merchantability or fitness for a particular purpose.

4.2. Total Liability Cap. In no event shall LX navigation, its directors, employees, or suppliers be liable to you or any third party for any direct, indirect, incidental, consequential, special, or punitive damages. This includes, without limitation, damages for loss of life, personal injury, loss of the aircraft, loss of business profits, or loss of data, whether under a theory of contract, warranty, or tort (including negligence).

4.3. Maximum Compensation. In no event will LX navigation's total aggregate liability to you for any and all claims arising out of the use of the system exceed the amount actually paid by you for the specific device giving rise to the claim.

20.5 Indemnification

You agree to indemnify and hold LX navigation harmless from and against any and all claims, actions, liabilities, losses, damages, costs, and expenses (including reasonable attorneys' fees) arising out of your improper installation, misuse of the device, or violation of any aviation regulations.

20.6 Governing Law and General Terms

6.1. Governing Law. This Agreement shall be governed by and construed in accordance with the laws of the Republic of Slovenia, without regard to its conflict of law principles.

6.2. Severability. If any provision of this Agreement is found to be void or unenforceable, that provision shall be severed, and the remaining provisions will continue in full force and effect.

6.3. Amendments. LX navigation reserves the right to amend this Agreement at its sole discretion by publishing updated documentation. Continued use of the device and software constitutes acceptance of the amended terms.

Contact

Headquarters

LX navigation d.o.o.
Tkalska ulica 10
SI-3000 Celje
Slovenia

VAT ID

Company is registered in Slovenia, EU under the VAT ID: SI40539601

US Office

LX navigation US
1704 Kennedy Point 1124
Oviedo, FL 32765
USA

Webpage

www.lxnavigation.com

Phone

+386 (0)3 490 46 70

Fax

+386 (0)3 490 46 71

Sales

sales@lxnavigation.com

Support

info@lxnavigation.com



LXNAVIGATION