

LX iris EFIS

[57 & 80]



Installation manual

- LX navigation -
May, 2025



Tkalska ulica 10
SI-3000 Celje
Tel.: 00 386 3 490 46 70
Fax.: 00 386 3 490 46 71
info@lxnavigation.com
www.lxnavigation.com

Contents

0 Document information	3
0.1 Abstract	3
0.2 Document status	3
0.3 List of applicable products	3
0.4 Revision history	3
1 Overview	4
2 Mounting	5
3 Wiring	6
3.1 Power supply	7
3.2 Static pressure (PST)	7
3.3 Total pressure (PTOT)	7
3.4 CAN bus	8
3.5 Outside air temperature (OAT)	8
3.6 Audio	8
3.7 GPS	8
3.8 Bluetooth/WiFi	8
3.9 FLARM	9
3.10 User	9
3.11 Inputs	9
4 Cut-out drawing	10
5 Technical specification	12
6 Environmental data	13
7 Conformity	14
8 Contact	15



Document information

0.1 Abstract

This document represents the installation manual for the LX iris EFIS. The user manual, release notes, dataport and additional info can be found on www.lxnavigation.com.

0.2 Document status

Document status: PUBLIC

Document status	Explanation
Internal	Intended only for LX navigation staff
Public	Available publicly to all
Personal	Intended for a specific person and/or company, noted on this page
Dealer	Intended for a specific dealer, noted on this page
Manufacturer	Intended for a specific manufacturer, noted on this page

0.3 List of applicable products

Device	HW Version
LX iris EFIS 57	1.0 - 1.7
LX iris EFIS 80	1.0 - 1.7

0.4 Revision history

Document name	Document revision	Date	Revised by	Approved by	Notes
LX_HIM	R1	9.1.2023	A.S.	N.S.	initial release
LX_HIM	R2	6.5.2025	B.D.	N.S.	minor changes

Overview

The **iris EFIS** is a modern primary flight display available in two versions:

- **iris EFIS** – Basic version
- **iris EFIS Pro** – Advanced version

Both versions share identical hardware; the only difference lies in the software feature set.

The iris EFIS includes a built-in battery, a voice module with audio alerts, Bluetooth, Wi-Fi, and support for wired connections to external devices such as an OAT probe, FLARM, and radio transceivers.

On the rear side, the iris EFIS features two pressure ports for connecting pitot and static pressures.

The iris EFIS is available in two sizes, designed to fit standard aviation instrument panel cutouts: **80 mm (3 1/8 inch)** and **57 mm (2 1/4 inch)**. The larger model uses a transfective display technology for improved sunlight readability.

Designed with simplicity in mind, the iris EFIS is operated via two push-buttons and two push/rotary knobs, providing intuitive and efficient control in flight.

Mounting

Tools needed:

- flat head screw driver,
- Philips screw driver,
- 8mm spanner.

Installation requires a standard 80/57 mm aviation size cut-outs. Please refer to **Cut-out drawing** to ensure fitting.

Follow the steps below:

1. Unscrew the two regular M4 Phillips head screws from the device.
2. Take the caps off of the push-rotary knobs (see figure 1).
3. Unscrew the flat headed screws from within the push-rotary knob while holding the push/rotary knob still by its black plastic. Pull the black plastic part off of the push-rotary shaft (see figure 2).
4. Unscrew the M5 hex bolts, enclosing the push-rotary shaft (see figure 3).
5. Place the device into its future place in the instrument panel.
6. Check that all of the holes are properly aligned and use M4 Phillips head and M5 hex bolts to hold device in place. Use supplied screws only.
7. Attach the rotary knob to the shaft. Make sure there is enough play between the rotary knob and instrument panel. Hold the knob with one hand and tighten the screw. Do not use any other tool to adjust the rotary knob. Put the top cover back. Test if there is enough play for the knob. It should rotate freely and when pressed jump back to its original position. If not, change the position of the knob on the shaft or adjust the size of the hole for the push/rotary shaft screw.

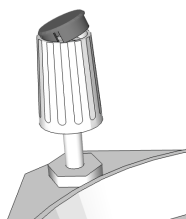

Figure 1. Step 2

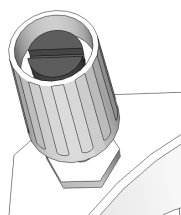

Figure 2. Step 3

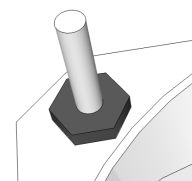

Figure 3. Step 4

Wiring

All needed cables are in the package. Some connections might not be available on your device and are optional upgrades.

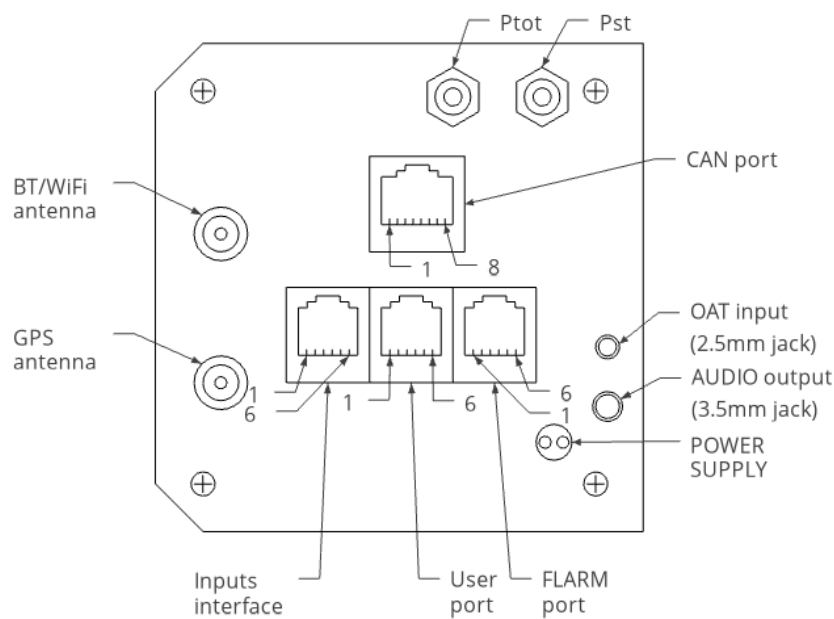

Figure 4. Instrument connections

User port (RJ11)		Flarm port (RJ11)		Inputs (RJ11)	
Pin number	Description	Pin number	Description	Pin number	Description
1	12 V out	1	12 V out	1	input 1
2	not connected	2	not used	2	input 2
3	not connected	3	GND	3	input 3
4	RS232 data in	4	RS232 data in	4	input 4
5	RS232 data out	5	RS232 data out	5	input 5
6	GND	6	GND	6	Common GND

CAN port (RJ45 - 8 pin connector)

Pin number	Description
1	12 V
2	12 V
3	12 V
4	CAN L
5	CAN H
6	GND
7	GND
8	GND

3.1 Power supply

LX iris EFIS requires DC power input in a range between 9 and 29 V DC. It is compatible with 12V and 24V aircraft systems. Use external fuse, as there is no fuse inside the unit. Apply power supply only to the main unit, as other units will get power over CAN bus. To provide the power to the system use supplied power connector. Blue wire is negative (GND) potential and red wire positive (9 - 29 V DC).

Prior to connecting the power to the device make sure that cables are tight and there is no short-circuits between wires. Plug the connector to the device. The device will turn on as soon as the main power supply is available. It will automatically charge the internal battery all the time. Recommended wire is 0.75 mm² AWG 18 or greater.

NOTE

Some units require pushing or holding the left push-rotary for device to turn on.

3.2 Static pressure (PST)

Connect the unit to the static pressure source. Static pressure source is obtained from the static port usually on the static ports of pitot tube or static ports on the fuselage.

Locate existing PST tube. If no free ports are available use T junction to split the tubes. Connect PST tube to PST port on the main unit.

3.3 Total pressure (PTOT)

Connect the unit to the total pressure source. Total pressure source is obtained from the total port on the pitot tube.

Locate existing PTOT tube. If no free ports are available use T junction to split the tubes. Connect PTOT tube to PTOT port on the main unit.

NOTE

Make sure the PST and PTOT tubings are airtight. It is highly recommended to keep the tubings as short as possible. The tubings must avoid sharp bends and twists. Water must not be allowed to enter the tubing.

3.4 CAN bus

CAN bus is used for communication with other units in the system as well as supplying power to these units. This allows indicators and second seat units to display the data from first seat unit. It allows the integration with other devices like LX Joy, iris series, etc. as well.

Use supplied shielded RJ45 1:1 cable to connect it with other LX navigation devices. CAN bus is compatible with LX navigation devices only.

3.5 Outside air temperature (OAT)

Connect OAT probe to the unit using the 2.5mm jack connector. Besides knowing the outside temperature at any given time, OAT probe is required as well to display true air speed (TAS).

Install OAT probe to the place with as little as possible heat influence from other components on the aircraft (heat from engine, direct sunlight, etc.). The ideal position is on the bottom part of the fuselage. Good alternative is air intake for the ventilation in the cockpit.

3.6 Audio

Connect the unit to aircraft intercom/audio panel using the 3.5mm jack connector Audio output. LX iris EFIS features active audio amplifier which is capable of delivering 1W of continuous power to 8 ohm passive speakers.

3.7 GPS

Connect GPS receiver antenna to the SMA connector on the back of the unit marked with GPS underneath. Install supplied antenna horizontally with "GPS" sign pointing to the sky. We supply high gain active antenna with superb reception. Despite that be careful with the placement. Do not install antenna under metal or carbon fiber instrument panel/cover. The antenna should have clear "sight" to the satellites. It can be covered with non-conductive material (eq. Glass fiber, glass, wood, cloth, etc.).

3.8 Bluetooth/WiFi

Connect Bluetooth/WiFi antenna to the SMA connector on the back of the unit marked with BT/WIFI underneath.

The GPS antenna should not be under any electrically conductive materials (metals, carbon fiber, etc.)

WiFi and Bluetooth connectivity enables LX iris EFIS to connect to 3rd party devices as well as connecting to LX Cloud.

The expected range of WiFi signal is up to 100 m and 20 m for Bluetooth.

3.9 FLARM

Connect FLARM device to FLARM port. The Flarm port uses standard Flarm pin-out in the 6-pin configuration. Use a 1:1 RJ12 to RJ12 cable.

Refer to the figure **Instrument connections** for the connector pinout.

3.10 User

Various devices can be connected to the LX iris EFIS's User port. The User port is used for bidirectional NMEA communication, using the RS 232 protocol. The list of devices is long, from PNA/PDA devices to radio transceivers.

Refer to the **LX Radio Transceiver Connections manual** for details on connecting radios.

Refer to the figure **Instrument connections** for the connector pinout.

3.11 Inputs

Connect Inputs interface to the Input port with 1:1 6 pin flat cable. The inputs interface incorporates slots for 5 external micro-switches. These micro-switches can trigger different functions and commands, as well as warnings.

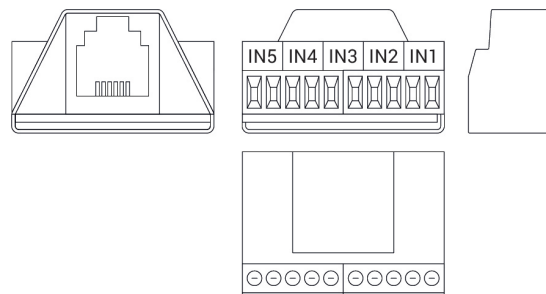

Figure 5. Inputs interface

NOTE

After finishing the installation, check that the device is completely working, prior to closing the instrument panel cover.

NOTE

If you run into any issues, contact us at info@lxnavigation.com for assistance.

Cut-out drawing

LX navigation uses standard aviation dimensions - 57 mm (2.25 inch) and 80 mm (3.125 in). Print this page on a regular or transparent paper to transfer the cut-out to the instrument panel.

Before cutting make sure, the dimensions are correct according to given dimensions indicated below. All dimensions are in milimeters.

Note that all units are in landscape orientation, meaning the push-rotary knobs are in the bottom two M5 holes.

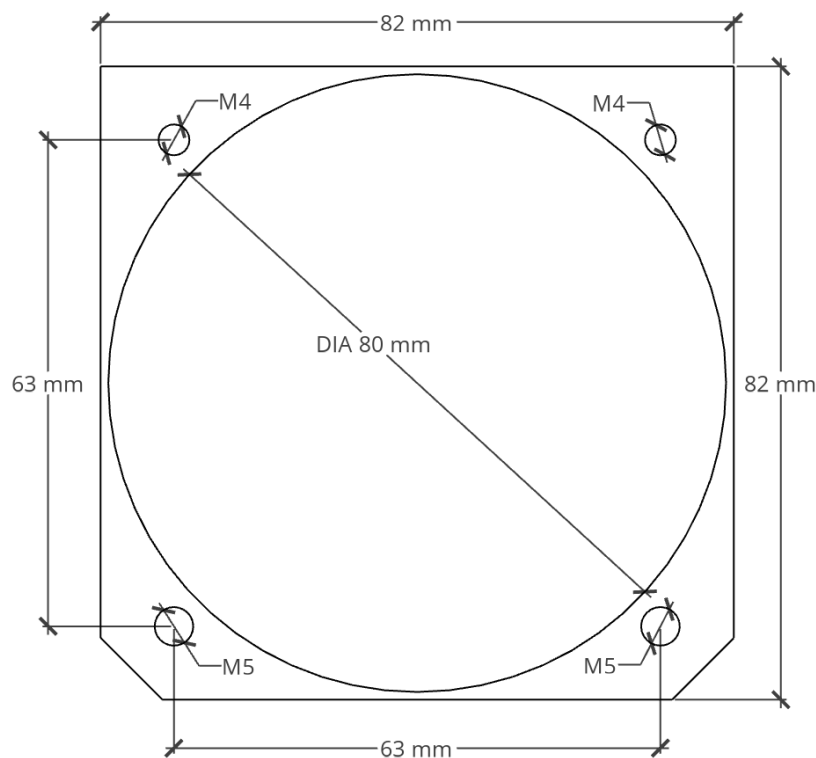

Figure 6. 80 mm cut-out template

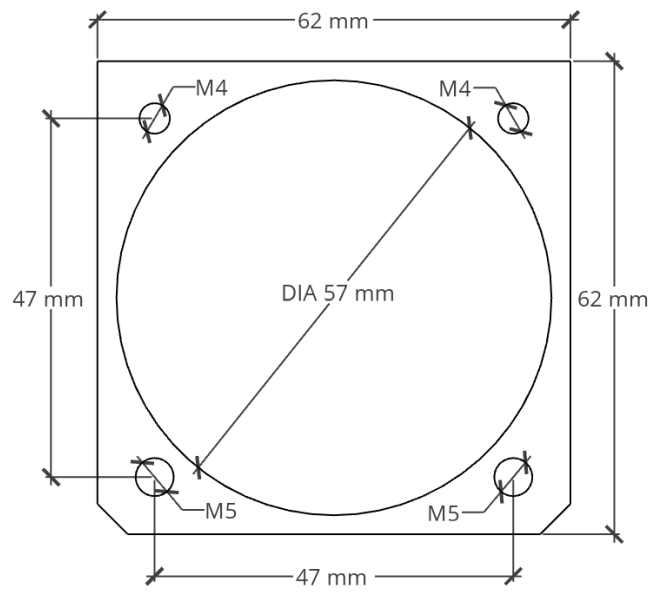

Figure 7. 57 mm cut-out template

Technical specification

Description	Unit	LX iris EFIS 57	LX iris EFIS 80
Dimensions	[mm]	62.2 x 62.2 x 98.5	82.3 x 82.3 x 69.0
Power supply	[V DC]		9.0 - 29.0
Nominal Voltage	[V DC]		13.8
Average Power Consumption	[W]		1.8
Mass	[g]	280	323
Mounting Panel Cutout	[mm]	57.0	80.0
Depth Behind Panel without Connectors	[mm]	62.6	49.0
Depth In Front of Panel	[mm]	20.7	19.0
Ground Survival Temperature	[°C]		-55 - +85
Operating Temperature	[°C]		-20 - +55
Relative Humidity	[%]		0 - 98
Max. Operational Altitude	[ft]		45,000
Operational Shock			6 g
Crash Safety Shock			20 g
Vibration			DO-160D U F/F1
WiFi range	[m]		100
Bluetooth range	[m]		20

Environmental data

Description	Section	Category	Conditions
Temperature / Altitude	4.0	D1	
Low Ground Survival Temperature	4.5.1	D1	-55 °C
Low Operating Temperature	4.5.1	D1	-40 °C
High Ground Survival Temperature	4.5.2	D1	+85 °C
High Short Time Operating Temperature	4.5.2	D1	+70 °C
High Operating Temperature	4.5.3	D1	+55 °C
In Flight Loss of Cooling	4.5.4	Z	No auxiliary cooling required
Altitude	4.6.1	D1	45,000 ft
Temperature Variation	5.0	B	
Humidity	6.0	A	
Shock	7.0	B	
Vibration	8.0	U/U2	Vibration curve F/F1 (robust vibration, helicopter)
Explosion Proofness	9.0	X	not tested
Water Proofness	10.0	X	not tested
Fluids Susceptibilities	11.0	X	not tested
Sand and Dust	12.0	X	not tested
Fungus Resistance	13.0	X	not tested
Salt Spray	14.0	X	not tested
Magnetic Effect	15.0	Z	less than 0.3m
Power Input (DC)	16.0	B	
Voltage Spike Conducted	17.0	B	
Audio Frequency Conducted Susceptibility	18.0	B	
Induced Signal Susceptibility	19.0	X	not tested
Radio Frequency Susceptibility	20.0	T	Radiated Susceptibility T
Conducted Susceptibility Emission of RF	21.0	M	Except intended operating frequencies (2.4/5 GHz)
Lightning Induced Transient Susceptibility	22.0	A2XXX	
Lightning Direct Effects	23.0	X	not tested
Icing	24.0	X	not tested
Electrostatic Discharge (ESD)	25.0	A	
Fire, Flammability	26.0	X	enclosure made of aluminum (Al) sheet

Environmental tests are performed in accordance with RTCA DO-160.

Conformity

Declaration of CE Conformity

Identification of product

LX iris EFIS (all variants)

Manufacturer

LX navigation d.o.o.
Tkalska ulica 10
SI-3000 Celje
Slovenia

Related standards

EMC directive 2004/108/EC

This product is designed to comply with standards/regulations and technical specifications stated above. This certificate is granted subject to the LX navigation quality rules on product certification.

Remark

The product is designed to comply with LX navigation standards and standards harmonized with directive 2004/108/EC: EN 55022:1998+A1:2000+A2:2003, class A; EN 55024:1998+A1:2001+A2:2003; EN 61000-3-2:2000+A2:2005; EN61000-3-3:1995+A1:2001+A2:2005



Contact

Headquarters

LX navigation d.o.o.
Tkalska ulica 10
SI-3000 Celje
Slovenia

VAT ID

Company is registered in Slovenia,
EU under the VAT ID: SI40539601

Webpage

www.lxnavigation.com

Phone

+386 (0)3 490 46 70

Fax

+386 (0)3 490 46 71

Sales

sales@lxnavigation.com

Support

info@lxnavigation.com