

# LX

navigation

## Zeus user`s manual version 4.2.0



## CONTENTS

<b>PART ONE – INTRODUCTION</b> .....	<b>5</b>
<b>1.1 Preamble</b> .....	<b>5</b>
<b>1.2 Operation</b> .....	<b>6</b>
<b>1.3 Installation procedure (LX Zeus and Eos/Era)</b> .....	<b>7</b>
Installation of LX Zeus .....	7
1.3.1 Installation of LX Eos/Era.....	7
1.3.2 Screen rotation.....	8
1.3.3 Connecting LX Zeus with LX Eos/Era .....	8
<b>1.4 Update procedure</b> .....	<b>9</b>
<b>1.5 Technical specifications</b> .....	<b>10</b>
LX Zeus 2.8 .....	10
LX Zeus 2.8 Retrofit .....	10
LX Zeus 4.3 .....	10
LX Zeus 5.5 .....	10
LX Zeus 7.0 .....	10
<b>PART TWO - SOFTWARE</b> .....	<b>11</b>
<b>2.1 Display organization and management</b> .....	<b>11</b>
2.1.1 Display organization .....	11
<b>2.2 Setup</b> .....	<b>14</b>
2.2.1 Setup .....	14
2.2.2 Pilot.....	15
2.2.3 Audio.....	17
2.2.4 LX Eos .....	18
2.2.5 Voice.....	20
2.2.6 Vario-SC.....	21
2.2.7 Indicators.....	23
2.2.8 Flarm.....	25
2.2.9 Logger .....	26
2.2.10 Airspace .....	27
2.2.11 Wind.....	28
2.2.12 Task.....	29
2.2.13 User interface .....	30
<b>2.3 System Setup</b> .....	<b>41</b>
2.3.1 Units.....	41
2.3.2 Glider .....	41
2.3.3 Checklist.....	46
2.3.4 Notepad.....	47
2.3.5 Transfer .....	47
2.3.6 Service .....	51
2.3.7 Localisation Settings.....	54
2.3.8 Brightness .....	55

<b>3</b>	<b>NAVIGATION MODES</b>	<b>56</b>
<b>3.1</b>	<b>Navigation in APT / TP or TSK mode</b>	<b>56</b>
3.1.1	Sort by filter	56
3.1.2	Main graphic navigation page	56
3.1.3	Second navigation page (1 <sup>st</sup> subpage)	57
3.1.4	Third navigation page (2 <sup>nd</sup> subpage)	58
<b>3.2</b>	<b>APT mode (navigation to airports)</b>	<b>58</b>
<b>3.3</b>	<b>How to select an airport?</b>	<b>59</b>
3.3.1	APT selection from NEAR function	60
<b>3.4</b>	<b>TP mode (navigation to turnpoints)</b>	<b>60</b>
3.4.2	Selecting Turn-points	63
3.4.3	Uploading TP photo	64
<b>3.5</b>	<b>TSK mode (navigation on task)</b>	<b>65</b>
3.5.1	Task organization	65
3.5.2	Task selection	65
3.5.3	Task creation by hand	66
3.5.4	Task Functions	69
3.5.5	MOVE Function (during flight)	71
3.5.6	Task Zoom	72
<b>4</b>	<b>AIRSPACE MANAGEMENT</b>	<b>73</b>
<b>1.1</b>	<b>Basic airspace settings</b>	<b>73</b>
4.1.1	Hide airspace above	73
4.1.2	Other settings	73
4.1.3	Define appearance of airspace related to zoom level	73
4.1.4	Disabling airspace sections	75
<b>5</b>	<b>GPS SIGNAL MANAGEMENT</b>	<b>76</b>
<b>5.1</b>	<b>Colibri II socket</b>	<b>76</b>
<b>5.2</b>	<b>Flarm plug</b>	<b>76</b>
<b>5.3</b>	<b>LX Eos – CAN plug</b>	<b>76</b>
<b>5.4</b>	<b>GPS signal for navigation</b>	<b>76</b>
<b>6</b>	<b>LX ZEUS AND LX EOS/ERA</b>	<b>77</b>
<b>6.1</b>	<b>LX Eos/Era power management</b>	<b>77</b>
<b>6.2</b>	<b>LX Eos/Era – Zeus interaction</b>	<b>78</b>
6.2.1	Commands and declaration transfer to LX Eos/Era	78
<b>7</b>	<b>LX ZEUS AND COLIBRI II</b>	<b>79</b>
<b>7.1</b>	<b>Colibri II power management</b>	<b>79</b>

**7.2 Colibri II – LX Zeus interaction ..... 79**  
 7.2.1 Commands and declaration transfer to Colibri II/Eos/Era ..... 79

**8 LX ZEUS AND FLARM ..... 80**  
 8.1 Flarm external displays ..... 81  
 8.2 Task declaration into Flarm..... 81  
 8.3 Transferring files from Flarm..... 81  
 8.4 LX Flarm RedBox / LX Flarm MiniBox update..... 82  
 8.5 Flarm PINOUT..... 82

**9 LX ZEUS AND GARRECHT ..... 82**  
 9.1 LX Zeus and Garrecht TRX-1090 ADSB / TRX-2000 ..... 82  
 9.2 LX ZEUS and Garrecht TRX-1500 ..... 82

**10 LX REMOTE STICK..... 83**  
 10.1 Use of LX Remote Stick..... 83  
 10.2 LX Remote Stick on second seat..... 83

**11 LX JOY ..... 84**  
 11.1 General..... 84  
 11.2 Button description ..... 84

**11 SECOND SEAT UNIT ..... 88**  
 1.1 Connecting Vario Indicator and LX Remote Stick ..... 88  
 11.2.1 Secondary Vario Indicator setup..... 88  
 11.3 Connecting LX Eos repeater to LX Zeus on second seat ..... 89  
 11.4 Interaction LX Zeus – LX Zeus Second seat..... 89  
 11.4.1 TSK / TP / APT exchange ..... 89  
 11.4.2 Downloading flights from Second seat ..... 89

**PART THREE – FLYING ..... 90**

**12 FLYING WITH LX ZEUS ..... 90**  
 12.1 Flight preparation on the ground ..... 90  
 12.1.1 Before take off ..... 90

<b>12.2</b>	<b>During flight</b>	<b>92</b>
12.2.1	Set MacCready (MC), Ballast, Bugs and QNH	93
12.2.2	Statistics	93
12.2.3	Follow me	96
12.2.4	Special functions	96
12.2.5	Task Start	98
12.2.6	Task Finish	100
12.2.7	Flying Assigned Area Task (AAT)	100
12.2.8	Final glide (FG) calculation	101
12.2.9	Finish line crossing	101
12.2.10	Thermal assistant	101
12.2.11	Flarm management	102
12.2.12	Attitude and heading reference system (AHRS)	103
<b>12.3</b>	<b>After landing</b>	<b>104</b>
12.3.1	Downloading flights	104
<b>12.4</b>	<b>ICAO charts</b>	<b>106</b>
<b>PART FOUR - MISCELLANEOUS</b>		<b>107</b>
<b>13</b>	<b>INSTALLATION (OTHER COMPONENTS)</b>	<b>107</b>
<b>13.1</b>	<b>Installation of LX Flaps sensor</b>	<b>107</b>
<b>13.2</b>	<b>Electrical installation</b>	<b>107</b>
13.2.1	LX Zeus with Vario (USB-D 60)	107
<b>13.3</b>	<b>Installation of second seat units</b>	<b>110</b>
13.3.1	Electrical installation	110
<b>14</b>	<b>EXPLANATION OF NAVBOX TERMS</b>	<b>111</b>
<b>15</b>	<b>FAQ (FREQUENTLY ASKED QUESTIONS)</b>	<b>114</b>

## PART ONE – Introduction

### 1.1 Preamble

#### **Why LX Navigation?**

LX Navigation is one of the oldest glider navigation brands. Its founders started experimenting with glider computers way back in the '70-ies and the Company has been working on improving your flight performance ever since.

Throughout the last 40 years or so it has been working on instruments that most pilots will have used at some time. In fact our equipment can be found in almost any gliding club !

Our equipment has always been ground-breaking.

Our motto?

***Be the first. Be the best. Be different.***

#### **Why Zeus?**

Because Zeus is a top of the line product. ***Crème de la crème.***

Used by pilots from all over the world, our instruments offer the best for both cross country soaring and competitions. The LX Zeus is the latest in this tradition.

#### **Devices**

We offer a wide range of instruments suitable for both club and competition soaring.

Our systems combine two components:

First, a glider computer (LX Zeus) which is used for calculating and displaying all of the key information used by pilots. This glider computer is the brain of the operation.

The second part of the system is a variometer (Eos, Helios, and Era). Its job is to gather the information which the Zeus uses. The vario has pressure connections as well as the GPS antenna connection which is required for IGC logs.

There is a wide variety of choice for varios and for LX Zeus display sizes.

All our varios are standalone devices which can be used without a glider computer for displaying basic flight parameters such as final glide information, Speed Command (SC) as well as simple navigation. Our varios also have an internal battery which means that your IGC logs do not depend on your glider's batteries.

System extensions (second seat unit, remote control (LXJoy), compass, NavBox, MOP, Flap sensor, AHRS ...) are also possible. Everything is connected using a CAN bus (single cable for power and data). All connections are plug and play, which means no specialist is required to install the system.

## 1.2 Operation

### Front panel interface

Communications between the pilot and the instrument is done via two rotary knobs and 8 push buttons.

All buttons and rotary switches have a double push function (short and long press). All buttons are labelled which makes unit manipulation very easy. The top labels are selected with a short press. Bottom labels are selected with a long press. On Zeus 2.8" and Zeus 4.3" there is a 4-4 button arrangement. On other screen sizes the button arrangement is 5-3.

Both rotary knobs are multifunctional as follows:

#### Default functions:

- Volume rotary knob
  - Volume adjustment function - scroll
  - Select (TP, APT, TSK) - short press
  - Shortcuts - long press
- Zoom rotary knob
  - Zoom adjustment function – scroll
  - Open more options (TP, APT, TSK) - short press
  - Edit NavBoxes – long press

#### In edit:

- Volume rotary knob: bigger steps when selecting values and escape/cancel by pressing it
- Zoom rotary knob: scrolling and press confirmation

### USB/SD

There are two ways of transferring files: either via USB or via SD port. A standard USB-A female port is available on each device (on Zeus 2.8 slim USB keys should be used). The port is exclusively used for data transfer and firmware updates. The micro SD port is only used when Flarm is connected (Flarm Red Box, Swiss Flarm and optionally Flarm Mini Box). The micro SD port is used for direct communication with Flarm, which means downloading flights stored on Flarm, uploading declaration and Flarm firmware updates.

### Back panel interface

On the back side of the unit there are the following connectors:

- 2x CAN bus\*
- 2x User ports
- Flarm port (12 V power and data) \*
- Flarm display output
- USB – A port

\* CAN bus connects LX Zeus to:

- LX Eos (57/80)
- LX Era (57/80)
- Second seat unit
- LX Joy
- LX NavBox
- LX Flaps sensor
- LX MOP
- LX AHRS

### 1.3 Installation procedure (LX Zeus and Eos/Era)

#### Installation of LX Zeus

The dimensions of larger units (4.3, 5.5 and 7.0) do not match air norm standards (57 or 80mm). A new cut out in the panel is necessary. There are two ways to prepare the panel:

The first option is to buy a new panel from the glider manufacturer and the second is to upgrade the existing panel. The user can also do a panel upgrade and, in that case, basic experience in fiberglass technology will help. (LX Navigation can provide additional instructions on how to rebuild the panel by yourself—just ask!)

Every unit (except the 2.8 inch, which fits an 80mm instrument hole) is supplied with a carbon which makes it possible to make the LX Zeus cut out by hand. If a CNC solution is planned, then please ask for .dwg file.



#### 1.3.1 Installation of LX Eos/Era

The unit occupies one 57 mm or 80 mm standard cut-out. The maximum dimensions of LX Eos/Era 57 are 60x60 mm max and they do not exceed the dimensions of classic pneumatic instruments. LX Eos/Era 80 mm are 82x82 mm max. LX Eos/Era is shallow, which means that there shouldn't be any problems installing it as regards space behind the panel.

**Note!**

Check labels near pneumatic connections on LX Eos/Era, during pneumatic tube connection process to ensure correct connection.



### 1.3.2 Screen rotation

The screen can be rotated by using password 9109 under Setup > Service > Admin password. The buttons must be rotated by hand. Follow the procedure below:

1. Open the unit (remove all screws and cover)
2. Move rounded rubber to the middle
3. Take out the button and rotate it to the proper position
4. Put button back on blue button (be careful that blue button is inside the black hose)
5. Put rounded rubber back to the first position (be careful with the Rotary knobs as the rubber must not be pushed all the way in)

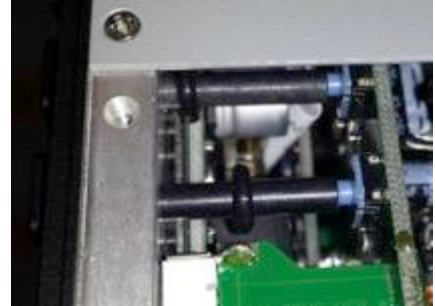

At this side the rounded rubber is touching the back plate of display, do not push it too tight

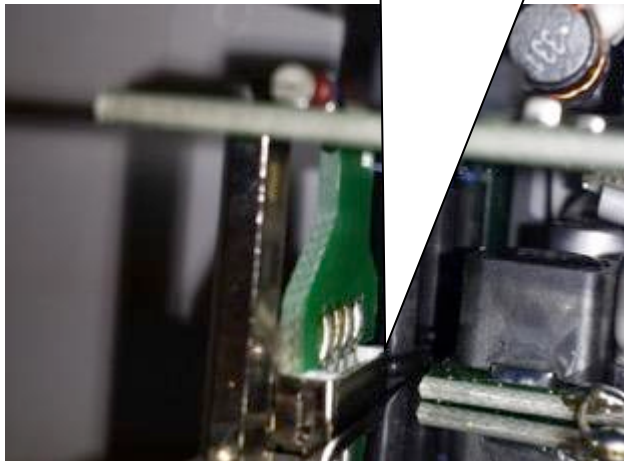

At this side the rounded rubber is pressed fully to the plate.

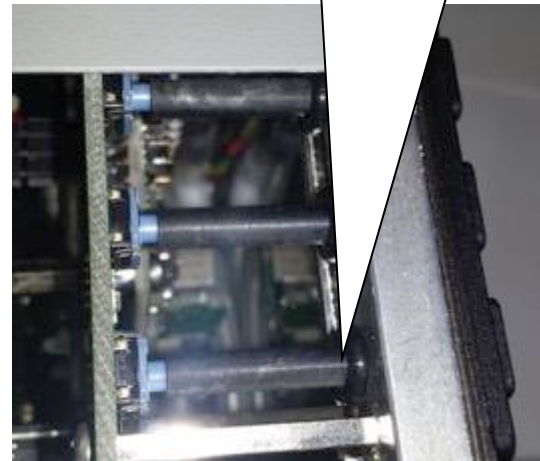

### 1.3.3 Connecting LX Zeus with LX Eos/Era

This part of the installation is easy and doesn't require any specialists. LX Zeus and LX Eos are connected via a CAN bus cable. Connect one end of the cable into Eos CAN bus port and the other into any of the CAN bus ports on the LX Zeus. LX Zeus receives power from LX Eos/Era. All data from and to LX Zeus and LX Eos/Era goes via a single CAN cable.

LX Eos receives power via two power lines, which should be connected to 12V glider power source and ground. The red wire is +12V and blue wire is Ground.

**Important!**

When LX Eos/Era is connected, the **terminator must not be connected to the system**, because there is a terminator integrated in LX Eos. Only one terminator should be used at once.

Connect supplied power cable with switch to 2-pole connector on LX Eos/Era.

LX Eos/Era and LX Zeus turn ON when the user switches the power ON. This is not the case if LX Eos/Era is a standalone version, which has different hardware and requires a push on the knob to turn ON.

For more information about LX Eos/Era refer to LX Eos/Era manual!

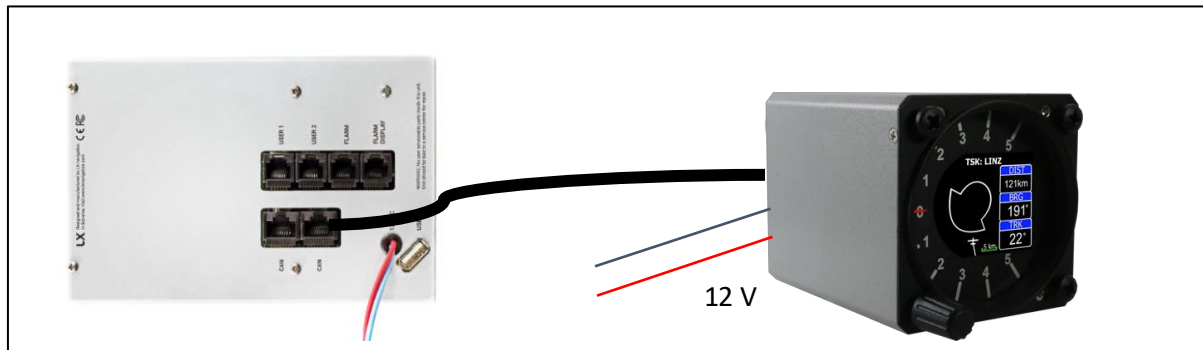

## 1.4 Update procedure

LX Zeus software is constantly being upgraded. Please contact your local dealer for the latest upgrade. The latest version, together with a change log, is always available on our website ([www.lxnavigation.com](http://www.lxnavigation.com)).

The upgrade procedure is very simple, just follow these steps:

- Put the upgrade file (Zeus-x.y.z.kus) onto a USB stick
- Insert USB stick into LX Zeus
- Turn on LX Zeus (If it is already powered on it should be restarted)
- Hold VARIO/FLARM button until the blue window opens
- Select upgrade with a push on the Zoom rotary knob
- Find the update on the USB stick
- Select the file with a push on the Zoom rotary knob
- Wait for installation, when an Initial setup screen shows then the update is finished
- All devices connected to CAN bus will be automatically updated
- In a Double-seater configuration the system may ask if this is FIRST or SECOND seat (confirm correct one)
- In case of Double-seater configuration repeat the whole procedure on the second seat LX Zeus

## 1.5 Technical specifications

### LX Zeus 2.8

This version of Zeus can be installed into any standard 80 mm panel cut out and therefore does not require an instrument panel upgrade. Display orientation is only landscape.

### LX Zeus 2.8 Retrofit

Zeus 2.8 Retrofit is the same display size as Zeus 2.8 but differs in hardware. Vario (USB-D) module is inside the main unit and only a vario indicator is needed. The back of the instrument is the same as for LX 5000 (2x 15pin connectors). If the LX 5000 had a 25-pin connector, an adapter for 2x15 to 25-pin is needed, which can be supplied from LX navigation. An old vario indicator can also be used. The attraction of the Retrofit solution is that all wiring remains as is.

LX Zeus 2.8 Retrofit is not available for purchase anymore so this instruction relates only to those pilots who have this system already fitted.

### LX Zeus 4.3

This version has a 4.3-inch display with 800x480px resolution and has the following outline dimensions:

- 83x136x52 mm

### LX Zeus 5.5

This version has a 5.5-inch display with 640x480px resolution and has the following outline dimensions:

- 106x146x52 mm

### LX Zeus 7.0

This version has a 7.0-inch display with 800x480px resolution and has the following outline dimensions:

- 110x190x52 mm

## PART TWO - Software

### 2.1 Display organization and management

The available information can be personalised and adjusted to meet the user's requirements and is set out in the following paragraphs.

#### 2.1.1 Display organization

LX Zeus display consists of the following:

- Geographic map.
- Bottom row (NavBox line).
- Header.
- Indicators.



#### 2.1.1.1 Indicators

Indicators are elements on the display which can be edited (existence, size, position, transparency). See **Setup/Layout** for details.

Here is a list of available indicators:

- Header
- Speed indicator
- Sliding speed indicator
- Speed indicator classic (circular)
- Digital speed indicator
- Variometer (bar)
- Variometer classic (needle)
- Wind indicator
- Final glide indicator (selected MC)
- Final glide (sel. MC, terrain aware)
- Final glide indicator (MC 0.0)
- Thermal assistant (available when you are circling)
- Compass
- Compass needle



- Compass assistant (assists the pilot when flying with a compass module)
- Airspace info (information about closest airspace. If no airspace is within selectable limits this indicator is transparent.)
- Limitations (Start conditions)
- Map scale
- AHRS
- Flaps position
- Follow indicator (shows position of a Flarm object being followed)
- Flarm indicator (used to show Flarm collision warnings. If no warning is available this indicator is transparent).
- Best alternate APT info (shows the pilot the best alternate airfield nearby (APT database) besides the one being navigated to). If no APT is available this indicator is transparent.

### 2.1.1.2 NavBoxline customization

The bottom row consists of customisable NavBoxes. This means that the pilot is able to create his own configuration. This simple procedure is also available during flight. The user can set different configurations for TP, APT and TSK navigation. It is possible to copy configurations from one page to another. (Done under Setup>Layout). The procedure starts with a long press on the Zoom rotary knob. After the long press a frame appears around the first NavBox. Rotating the Zoom rotary knob positions the frame. When the desired frame position is reached, a short press of the Zoom rotary knob again will open a list of available NavBoxes.



### 2.1.1.3 List of available NavBoxes

#### **SPEED**

- Indicated air speed
- True air speed
- Ground speed
- Vario
- Average vario
- Netto vario
- Average netto vario
- Relative vario
- Optimum speed to fly

#### **ALTITUDE**

- Altitude QFE
- Altitude QNH
- Altitude QNH in ft
- Maximum altitude QNH
- Altitude IGC
- Altitude GPS
- Above ground level
- Flight level
- Thermal gain
- Thermal last 30
- Thermal average
- Thermal all
- Set MacCready
- Required MacCready
- Sink speed
- Final glide (selected MC)
- Final glide (with terrain)
- Final glide (MC 0.0)

#### **TASK**

- Time on task
- Time on leg
- Time to go
- Required speed
- Task speed
- Task speed in last hour
- Task elapsed distance
- Task remaining distance
- Task delta time
- Team code
- Team bearing
- Team distance
- Leg speed
- Task distance

#### **GENERAL**

- G-force
- Circling radius
- Last full turn time
- Recommended flaps position
- Current flaps position
- Wind speed
- Wind direction
- Air temperature
- Distance in NM to selected TP/APT
- Distance to selected TP/APT
- Off course distance
- OLC distance
- OLC home distance
- OLC speed
- OLC speed in last hour
- OLC score
- Horizontal distance from airspace
- Vertical distance from airspace
- Arrival QFE (no reserve)
- ETE - Estimated time en-route
- Current efficiency
- Average efficiency
- Required efficiency
- Track
- Bearing
- Radial TP/APT
- Compass heading
- Digital clock
- Analog clock
- Flying time
- ETA (current speed)
- ETA (average speed)
- ETA (McCready speed)

To terminate the process, press the Volume rotary knob (“Go back”).

Up to nine bottom rows can be used selectable with **1-4** push buttons. To create a new row simply press 1-4 and a new row will open. The display configuration may consist of one, two or three NavBox rows. See Setup/Layout for details.

### 2.1.1.4 Header

The header cannot be customized. Only the transparency can be set: go to Setup>Layout. From left to right there is information about:

- Current navigation page (TSK, TP or APT)
- Current navigation turn-point
- Distance and steering information to get to the navigation point
- LX Joy status (N = normal, Z = zoom, P = pan)
- Battery status
- GPS signal status
- Current time in selected format (hh:mm:ss)

## 2.2 Setup

### 2.2.1 Setup

The setup menu is available after a short press on the push button labelled **SETUP**. The menu is divided into two sections (Pilot and System settings). **System settings** are settings that are valid for the whole system and are not pilot specific settings. Pilot settings may vary from pilot to pilot according to individual requirements. Icons with text will help in finding the menu of interest.

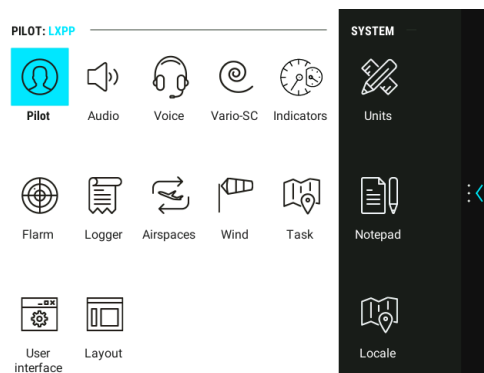

- Use Zoom rotary knob and rotate it to find the menu of interest (selected icon is highlighted)
- Use push function of Zoom rotary knob to enter menu

#### 2.2.1.1 Pilot specific settings

The data stored in this part of Setup is pilot specific data. After pilot selection on initial setup, the data of an individual pilot becomes active. All settings are saved to the pilot profile and are active when the pilot is selected (reserve altitude, logger settings, NavBox container, layout settings, task colours etc.) It is possible to export/import user profile settings with a USB stick.

**Note!**

All settings active at the moment of new pilot creation under “Pilot” will be adopted.

### 2.2.2 Pilot



Pilot

The Pilots **name** and certain personal data can be stored. All stored pilot names will be offered during initial setup and selecting a pilot is mandatory. The system offers a default user profile with the name

**DEFAULT** which can be used as a default pilot. Furthermore, plenty of empty positions are offered and this can be used for another pilot using the instrument. Some additional parameters can be entered, such as pilot's **weight**, **default ballast** and **reserve altitude** – all settings are used for final glide calculation.

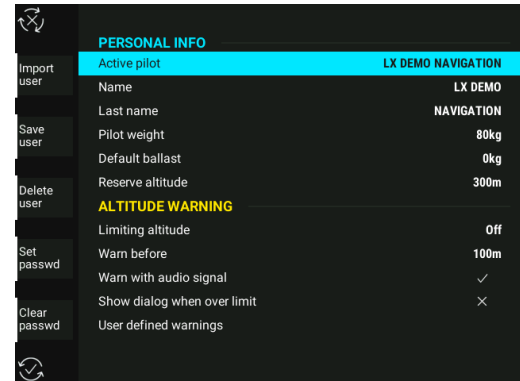

#### TDT calculation (task delta time)

This information is shown in a NavBox and presented only if the task time has been set. If task time is set the unit will recognize this task as assigned area task (AAT). The purpose of TDT is to inform the pilot of early or late arrival to the finish line/cylinder.

For TDT calculation one can choose between 4 different options:

- Average task speed is based on current task speed
- MacCready is based on actual based MC value
- Ground speed is based on average ground speed in last 20 seconds
- Combined (default) is based on multiple parameters including: selected MC, wind speed/direction, polar, bugs, ballast, reserve altitude. This is the recommended method for calculation

#### AAT calculation

To help the pilot optimize distance inside a sector there are equidistant lines displayed. They are shown inside the active zone. This feature is only available in automatic AAT mode. Flying along these lines will not increase the distance and may lose time on task. Ideally one should fly perpendicular to the lines.

AAT calculation offers two options:

- Automatic (default)

This method doesn't need any pilot assistant at all and the pilot can turn to next turn point at any time without using any commands. Zeus will automatically detect the optimum point in every sector on task. Switching to the next turnpoint is performed by:

- Reaching the line which is crossing the centre of the sector or a moved turnpoint. Reaching this point will only switch navigation to next turnpoint (for your information). One can still proceed inside this sector and Zeus will find the optimum position inside the sector to start the new leg. A new leg in statistics will start automatically when the optimum point is reached.
- Leaving an active sector. When the glider is more than 5km out of the sector it will switch. This is done only if there was no automatic switch inside the sector (you did not cross the line over centre of the sector or moved point) or if the next Next TP button was not pressed manually whilst inside the sector.
- Using Next TP button. This command can be used without influencing statistics. It will only change navigation data.



- Manual switching requires specific action in every sector on task. The Next TP button has to be pressed to switch to next Turnpoint. The position at which Next TP button was pressed is then used for task statistic calculation. In the case of a wrong decision the pilot should use the leg restart function and, when he is ready again, he should then press next TP.

### Limiting altitude

Limiting altitude means altitude limit set that will turn on the altitude warning alert.

When this is set, the pilot can choose:

- Warn before
- Warn with audio signal
- Show dialog when over limit

### User defined warnings

The pilot can make user defined warnings, which will give an alert when the conditions assigned have been fulfilled.

To make a user defined warning go to Setup > Pilot select User defined warnings and select “add new”.

1. Then can be defined:
  - Conditions check frequency (How often Zeus checks if the conditions are fulfilled).
  - Repeat interval (How often should the warning be repeated).
  - Auto close after... (the length of time the warning should remain before disappearing).
2. To add the text to appear on the screen as a warning, select Text, and add the desired text.
3. The final step is to add conditions (one or more) which will determine when the warning appears:
  - Choose a parameter (Choose from - flight time, air temperature, ballast, air speed, QFE altitude, battery voltage, distance to destination (to current TP or APT)
  - Operator (Choose relation to the reference parameter)
  - Value (depending on chosen parameter)

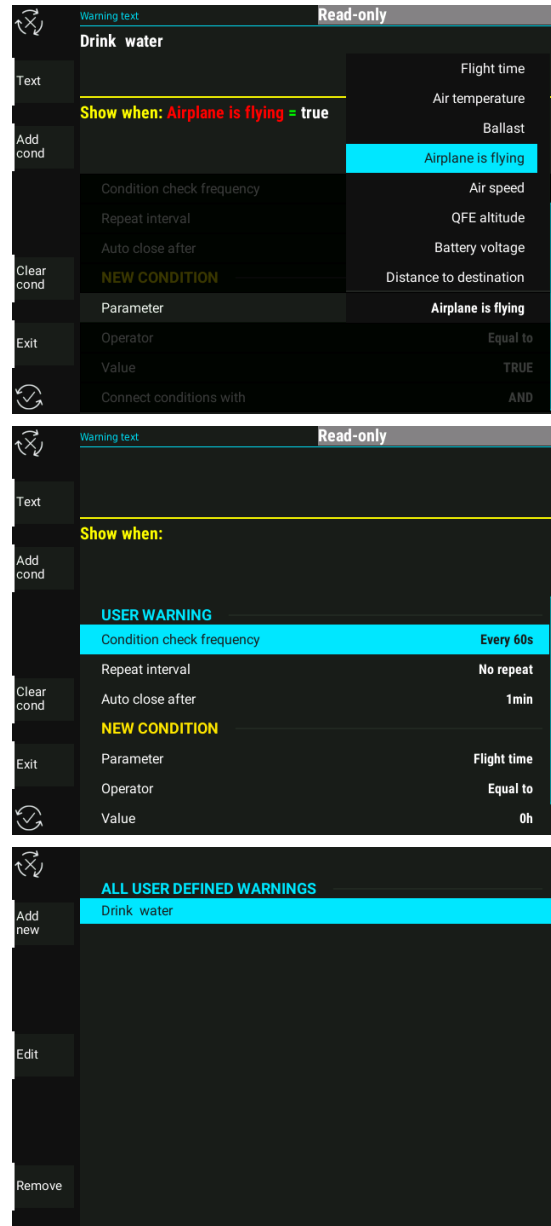

- Connect condition with (if there is more than one condition, select what conditions are to be connected with AND or OR)
- When your condition is complete select “Add cond” (if you want to remove it, select “Clear cond”).
- When finished select Exit

It is possible to edit all user-defined warnings, and to delete them.

### Other useful information

User (pilot) settings can also be saved to the USB stick and importing a user done by pressing the buttons: **Import user** (VARIO/FLARM) and **Save user** (TSK/MOVE). There is also an option to a **set password** to each pilot profile to prevent other pilots flying with the same unit and changing the pilot settings (this function was specially developed for flying in clubs). After a press on **clear password** the password will be removed. To delete a user, simply select **delete user**.



### Audio

#### 2.2.3 Audio

This menu defines audio configuration. The audio generator is a part of the vario unit (USB D 60), but settings are stored in LX Zeus. Audio settings do not appear if there is a LX Eos connected to the system.

Instead there is a LX Eos icon where the LX Eos can be set up. For more information please check the LX Eos chapter.

Speed command mode:

- Defines audio in SC. The most commonly used setting is both which means SC will beep in both positive and negative deflections

Speed command volume:

- Defines audio volume in SC; it may be increased or decreased

Vario tone:

- Defines audio in vario mode; the frequencies can be adjusted and also the types of audio; use Test vario after adjustment

Alarm: The audio generator is also capable of generating some alarms (warnings) combining two frequencies. Set frequencies and time intervals and use Test to check.

AUDIO LUKA	
GENERAL AUDIO	
Speed command mode	Both
Speed command volume	High
Vario tone	Linear positive
Zero frequency	500Hz
Positive frequency	1500Hz
Negative frequency	200Hz
Test vario sound	
ALARM	
First frequency	3000Hz
First frequency duration	300msec
Second frequency	2000Hz
Second frequency duration	300msec
Repetitions	10
Next alarm	3min
Test alarm	



### 2.2.4 LX Eos

All settings for LX Eos are done on LX Zeus.

#### LX Eos

LX Eos settings appear only if LX Eos is connected to LX Zeus, otherwise, there are audio settings for vario (see previous chapter for more information).

If the battery is too empty for the LX Zeus, the LX Eos will still work because it has an internal battery. In this case, settings for LX Eos are set on the LX Eos device (for settings on LX Eos see LX Eos manual)

#### Warnings

Warnings are used to inform the pilot that some flight related data is outside the desired margins. When a LX Eos detects a warning state, the pilot will get a red warning message box with a description of what is outside the margins.

By ticking the box the pilot can enable audio and Flarm warnings.

LX EOS WARNINGS	
Audio	✓
Flarm	✓
Inputs	✗
Altitude	5000m
Stall speed	70km/h
Vne speed	290km/h

- **Audio:** If disabled, voice warning will not be generated – the only warning will be visual in message box.
- **Flarm:** Flarm warning page will be seen only on the Flarm radar page if this flag is disabled, otherwise it will override any Eos page/menu when a warning is detected.
- **Inputs:** Must be turned on to enable input port warnings such as airbrakes, gear etc
- **Altitude:** Warning when flying above a selected altitude.
- **Stall speed:** Warning when the glider speed is lower than stall speed.
- **Vne speed:** Warning when speed exceeds Vne.

#### Audio

Variometer sound frequency can be changed.

Negative frequency means the frequency when the variometer indicates sink of -5.0m/s (-10 kts).

Zero frequency is frequency when variometer indicates 0.0m/s.

Positive frequency is frequency when variometer indicates climb of 5.0m/s (10 kts).

### Inputs

LX Eos offers the possibility of five different user defined inputs. Each input can be set accordingly.

There are seven options to choose from:

- None: nothing is connected to the input.
- SC: the device changes mode from vario to SC mode
- VP: (vario priority) the device goes to vario mode no matter what the SC is selected to
- Event: an event when a flight recorder is activated and pilot gets a message shown on display
- Gear: If enabled under warnings, warnings will be generated such as gear up/down warnings after takeoff / before landing
- Airbrakes: if enabled under warnings, will generate airbrakes warning if they are opened during takeoff

LX EOS INPUTS		
Input	Type	Mode
1	SC	Normal
2	VP	Normal
3	event	Normal
4	none	Normal
5	none	Normal

The pilot can also select if the switch is working in normal mode or if it is working in inverted mode. Normal mode means that the switch is enabled when contact is closed, inverted means that switch is enabled when contact is opened.

If two or more inputs are the same, the corresponding action will be made when all of them are active (active = switch opened!). The answer as to how to connect switches to external switch interface, and what “active state” is, can be found in the external switch installation section of LX Eos manual.

### NMEA

This setup page is used to set what data is sent to a third-party unit connected through Bluetooth or USER port. The pilot can set baud rate (BR) for communication through the USER port or Flarm port.

The pilot can select from: BR4800, BR9600, BR19200, BR38400, BR57600 and BR115200 options.

LX Eos is capable of sending NMEA data to third party units such as PDAs or PNAs. The data is available on the connector marked as USER and Bluetooth port. Five data strings are offered. Selected (check box) NMEA data will be sent over the USER port and Bluetooth:

- GPGGA – Global Positioning System 3D-Fix Data
- GPRMC – Recommended Minimum Specific GPS/TRANSIT Data
- GPRMB – TP navigation info

LX EOS NMEA BAUDRATE	
User	38400
Flarm	19200
NMEA OUTPUT	
GPGGA	✓
GPRMC	✓
GPRMB	✓
LXWPx	✓
PFLAx	✓
Radio	None
Transponder (Flarm port)	✗

- LXWPx – sentences contain pressure and altitude information in addition to IAS data
- PFLAx – Flarm traffic info. Data must be enabled, if Flarm data is required on a PDA
- Radio – Select which radio is connected to Eos USER port. KRT2 and ATR833 were tested and are supported at the moment. Baud rate on USER port is automatically set to 9600

**Note**

When Radio option is enabled (KRT2 or ATR833) all other outputs on User port are disabled, but are still present on Bluetooth port.

**Pages**

The pilot can select which main pages are active on LX Eos.

A page is active when its box is checked.

There are five main pages available:

- TA (thermal assistance)
- Flarm
- TP (turnpoint)
- TSK (task)
- GPS info (basic GPS information)
- AHRS (if AHRS module is connected)



2.2.5 Voice

In the case of LX Eos, or if LX Voice Module is a part of the system, the following settings can be used: If Enable all or Disable all are pressed the pilot can enable / disable all voice commands at once.

**Voice**

**Volume:**

- Voice volume: defines volume of voice messages
- Vario mixer: defines the balance of volume between Audio and Voice

**General Information:**

- Enable or disable general information about pilot, glider and elevation

**Task Information:**

- Enable or disable information about task, turn point, final glide and time

**Warnings:**

- Enable or disable warnings

**Flarm:**

- Enable or disable information about Flarm and warnings

## 2.2.6 Vario-SC



Settings in this menu define vario characteristics and some other important inputs connected to vario and speed command.

### Vario-SC

#### Vario:

- Vario filter defines the dynamics of the vario needle. Lower number means faster reaction and vice versa.
- Integration time (displayed on vario unit) The time period used for the integrator
- Vario scale, three options (2.5, 5 and 10 m/s) (or 5, 10 and 20 kts, if selected in Units).

#### Other:

- Silence range, defines range of no audio around zero when in speed command
- SC switching threshold, changeover speed at which it will change from Vario to SC if Automatic SC switching is enabled
- Automatic SC switching, defines speed parameters for automatic change over to SC
- External switch mode\*, determinates external SC switch status which change over to SC

VARIO SC LUKA	
VARIO	
Vario filter	1.5s
Smart vario	Off
Integration time	20s
Vario scale	5 m/s
OTHER	
Silence range	1.0m/s
SC switching threshold	100km/h
Automatic SC switching	Disabled
External switch mode	On

#### \*LX Zeus-LX Eos

Connect the external switch of input interface, which is connected to the input port on the rear of LX Eos. It does not matter to which of the 5 inputs it is connected. Then go to the Setup page on Zeus and navigate to LX Eos page. Next go to input and select one input as the SC option.

Next, go to Vario-SC setup:

Setting the **External switch mode** to **ON** means that closing the switch will enable SC mode, and setting **External switch mode** to **OFF** means that closing the switch will select Vario mode. There is a third option that can be enabled by setting **External switch mode** to **Toggle** and connecting a push button. Now each press will toggle between SC and Vario (This is the obligatory setting when using the LX Remote or LX Joy).

**\*LX Zeus-USB D 60:**

LX Zeus has a connection for an external speed command switch, which is **wired to the vario unit (USB D 60)**. By using an external switch, it is possible to switch between SC and Vario manually. Setting the **External switch mode to ON** means that closing the switch will enable SC mode, and setting **External switch mode to OFF** means that closing the switch will select Vario mode. There is a third option that can be enabled by setting **External switch mode to Toggle** and connecting a push button. Now each press will toggle between SC and Vario (This is the obligatory setting when using the LX Remote).

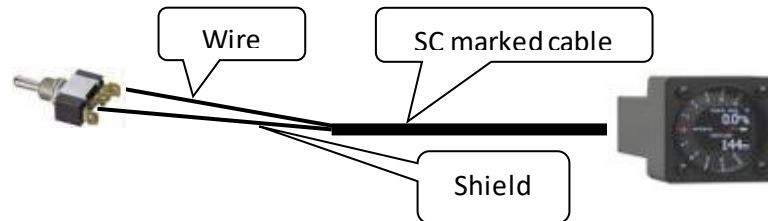

Wire	Shield	<b>Open</b>	Setting: ON	Status: VARIO
Wire	Shield	<b>Open</b>	Setting: OFF	Status: SC
Wire	Shield	<b>Closed</b>	Setting: ON	Status: SC
Wire	Shield	<b>Closed</b>	Setting: OFF	Status: VARIO

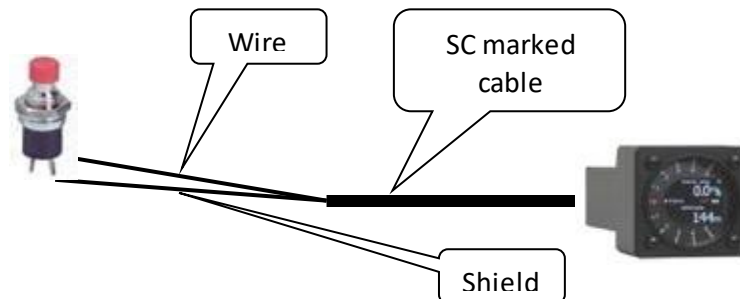



### 2.2.7 Indicators

#### Indicators

The indicators page is used for setting up varios with mechanical needles and colour graphic displays. One indicator is defined as a variometer. The system is capable of driving secondary indicators identified as “Number 1” through to “Number 4”. For LX Eos repeater, connect it to Lx Zeus second seat CAN bus port.

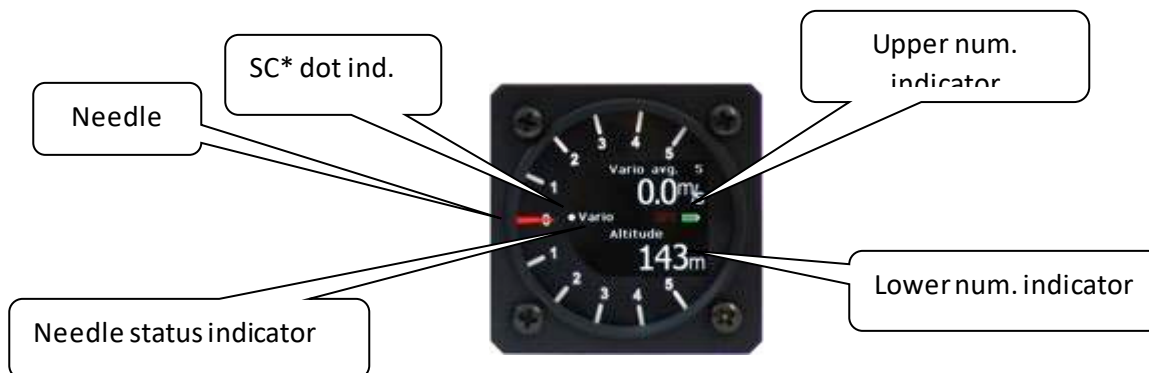

In general, every indicator consists of a mechanical needle, SC dot, needle status indicator, upper/lower digital indicator, battery indicator and a GPS signal indicator. It is important to point out that the settings should be done separately for vario and SC mode of operation. A radial moving dot serves as a continuous speed to fly indicator; this cannot be changed. On the LX Eos, there is a radial moving arc that serves as a speed to fly indicator. Additionally, there are GS (ground speed) and wind indications, plus some other status icons (Flarm, Bluetooth, etc.) which cannot be changed.

#### Used terms explanations:

- Vario needle: means the needle function in vario mode, alternatives are: vario, Netto\*, SC, Relative\*\*
- SC needle: means the needle function in SC mode, alternatives are: Netto, Relative, Vario
- Vario upper No.: means the display indication with option of: integrator, time, flight time, leg time
- Vario lower No.: means the display indication with option of: altitude, distance, glide difference, true air speed, leg speed, QNH, flight level
- SC upper No.: means the display indication with option of: integrator, time, flight time, leg time
- SC lower No.: means the display indication with option of: altitude, distance, glide difference, true air speed, leg speed, QNH and flight level

\* Vertical speed of air mass

\*\* Vertical speed –0.8 m/s

#### Note!

Setting **Altitude QNH ft** sets Altitude indication in ft, no matter what is set in Units.





INDICATORS	
Vario needle	Vario
SC needle	SC
Vario upper number	Vario Avg.
SC upper number	Vario Avg.
Vario lower number	Altitude
SC lower number	Distance TP

### 2.2.7.1 Secondary indicators

Secondary indicators should be connected via the 485-system bus; there are three 9P connectors at the back of the unit. All contacts are in parallel so it doesn't matter which one is occupied. The unit can be also used as a 485-system bus splitter. To define indicator number use **DIP switches** which you find at the back of the unit.

**Note!**  
Units having Adr1 will simply repeat what is displayed on the vario. Higher addresses make different settings possible.

Number	Switch
IND 1	x x
IND 2	x x
IND 3	x x
IND 4	x x

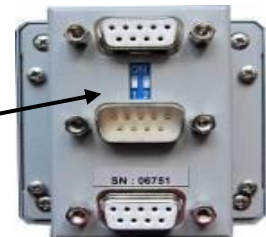

**Note!**  
Indicators installed for the second seat should be connected to front seat with 485 bus

Once indicator functions have been defined, switch the unit off and then on again, this procedure will memorize the settings and it will then be possible to adjust the settings on LX Zeus.



## Flarm

### 2.2.8 Flarm

This menu is used for changing the Flarm visualisation parameters. The only executive command which can be sent to Flarm unit is privacy mode.

Activation of privacy mode will send the Flarm unit into “stealth mode”, which means that the data transmitted to and from Flarm unit is limited.

Others commands are:

- Show objects till zoom defines the distance at which a Flarm object appears on the map
- Rel. altitude interval sets the altitude difference for a Flarm object to appear
- Glider icon size
- Airliner icon size (any powered aircraft)
- Show Flarm tails
- Tail colour
- Tail width
- Use above/below colour coding (makes it possible to define the colour for above and below Flarm objects)

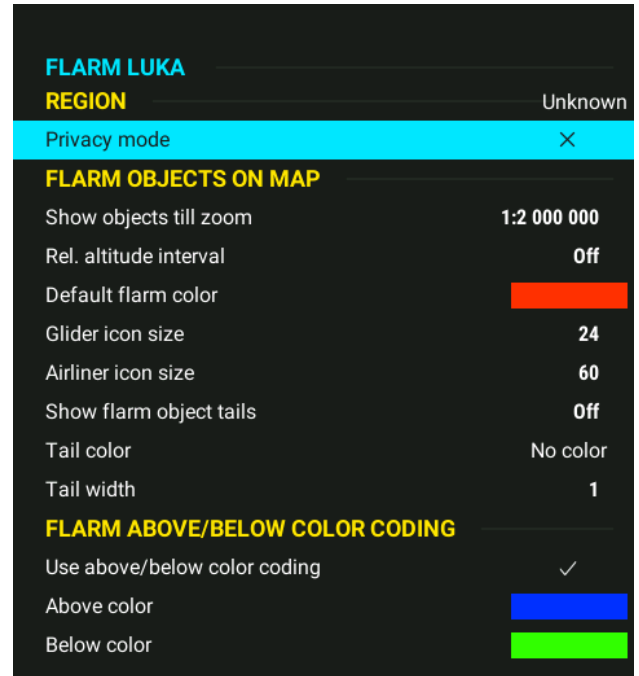



### 2.2.9 Logger

#### Logger

LX Zeus uses LX Eos and/or Colibri II as an IGC approved flight recorder. Both units collaborate so that all necessary settings can be sent to all flight recorders connected to the system (LX Eos, Colibri II). No action is required on LX Eos and Colibri II when flight recorders are connected to LX Zeus.

Recording interval is set to 5 seconds by default. Event repetitions are set to 20 and event fix interval to 1 second. This means that when press “Event” button is executed the logger will create 20 records in 20 seconds (one per second).

The extra recording option means that you can select the recording of Ground speed into log file.

**This menu is usable only if LX Eos and/or Colibri II is connected to LX Zeus. If settings are changed, they will not affect Flarm IGC or any other connected Flight recorder.**

LOGGER LUKA	
<b>BASIC</b>	
Recording interval	5s
Event fix interval	1s
Event repetitions	20
Class description	
<b>EXTRA RECORDINGS</b>	
Extra recording 1	None



In a double seat configuration, the second seat pilot is also able to change flight recorder settings. The process is the same as for the first seat.

#### Note!

Pilot and glider data are sent after task **Declaration** process has been executed. See section Flying.



### 2.2.10 Airspace

All settings connected to Airspace management are available in this menu.

## Airspaces

**Note!**

**Hide above airplane** option will remove airspace sections which are higher than the setting. This will reduce the clutter on the graphic page significantly.

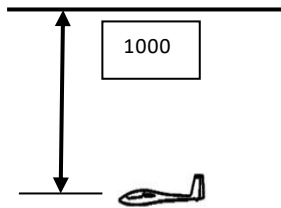

Example of Hide airspace above :

- The maximum vertical and horizontal distance to which airspace in Airspace info box on map is displayed can be set. If there isn't any airspace that fulfil these conditions the Airspace info box will not appear
- Hide above QNH altitude to disable airspace that is above set QNH altitude
- Audio warnings (on vario) when airspace warning appears on the LX Zeus can be dismissed (dismiss buttons)

Default warnings for airspace are set to 2 km horizontally and 100 m vertically but these warning settings can be adjusted. Warning timeout at take off is pre-set to 5 minutes, which means, that during the first 5 minutes after take off there will not be any airspace warnings.

**Show on zoom**, defines appearance of particular airspace sections on the display. Appearance is connected to zoom. Airspace warning can be set as active (☑) or as not active (☒).

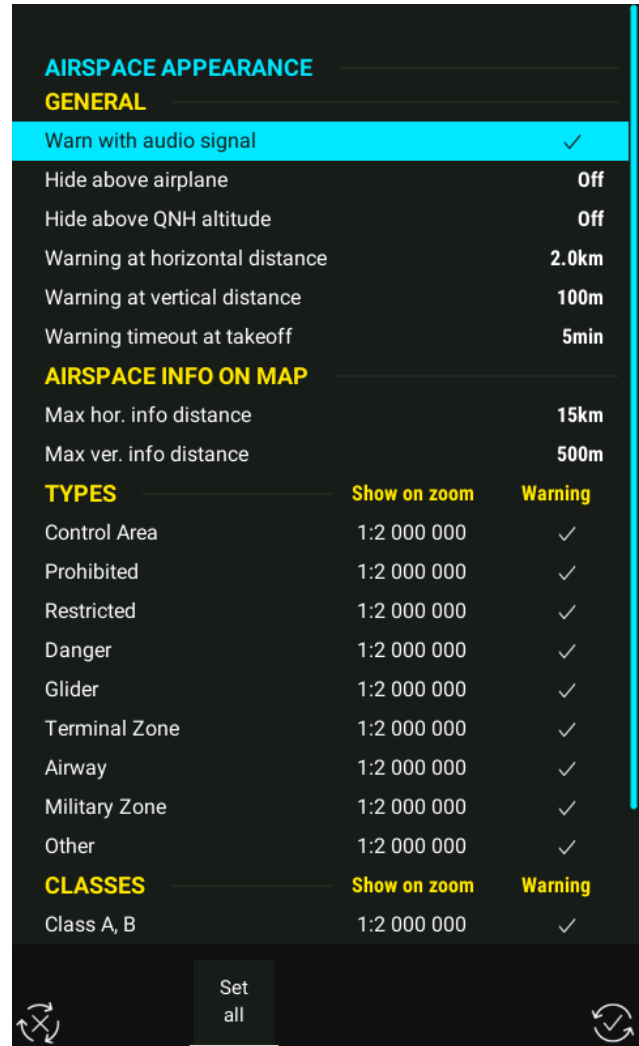



Wind

### 2.2.11 Wind

LX Zeus is able to measure wind using different methods; these can be selected in the **Wind** menu. Wind calculation results are shown as a standalone indicator on the

main graphic page and also as a NavBox, if set.

The pilot can choose between two circling methods: one which measures wind during circling flight and the second method using straight flight. The wind calculation is used for numerous calculations (TDT, Final glide, etc.).

WIND SETTINGS	
Circling model	Speed difference
Straight model	Iterative
Time for straight flight	15s
Drift circles	6
MANUAL WIND SETTINGS	
Set manually	X
Speed	0km/h
Direction	360°

#### 2.2.11.1 Circling model

- **Speed difference** is based on the variation of ground speed (GS) using the wind detected whilst in circling flight. This method is only active during circling. (In straight flight the wind data remains unchanged). The process is started automatically once circling is detected. After two circles the wind indication (direction and speed) will be updated and displayed. This method is based on the ground speed being affected by the wind. GS is, of course, at its maximum with a tailwind and minimum with a head wind and this is used for the GS difference calculation method. To get a result the pilot should do two turns as a minimum, more turns will improve the result. Please note that up to 90 degrees turn or more is required as some time is needed to detect circling status. **It is important to keep constant IAS speed during circling.** However, other factors are also taken into account to cancel out the fluctuations of airspeed while circling. This wind calculation method is the default and preferred approach.
- **Position drift** calculates wind regarding to position change during circling. Such a method needs more circles than speed difference (from 4 up to 8). The number of circles should be set in **Drift circles** option. If both methods, straight model and position drift are selected, the Zeus will give a combined result.

#### 2.2.11.2 Straight model

- **None:** If you select none, you will have the wind from the latest circling method.
- **Iterative:** This method will update the wind in straight flight. It is a special method developed by LX Navigation and delivers accurate wind measurements by using sophisticated algorithms. With this method, you do not need a compass. The pilot will, however, get good wind speed and direction results. This method does not supplement Head/Tail method and, for best results, a constant IAS is required.
- **Compass:** The Compass system requires the compass module to be connected to the unit using the 485 bus or CAN bus. Wind calculation is based on the wind triangle method. Under this approach, airspeed, ground speed and wind create a triangle of vectors. A compass device offers magnetic heading, which defines the direction of the airspeed vector. To measure wind using a compass straight flight speed and direction must be kept as stable as possible.

**\*Compass module** is a standalone electronic device, which can be connected to LX Zeus via 485 bus (or CAN bus for newer versions.) The unit delivers the magnetic track to the LX Zeus. However, to get accurate measurements, it is essential to have good compass calibration.

**Note:**  
Compass option is available only if the compass module is connected.

- **Head/Tail:** Shows difference between GS and IAS.
- **Time for straight flight:** Time in seconds that will be taken for one measurement (valid for straight model). The longer the period the better the result. This is valid only for the compass method and not for the Head/Tail one.
- **Drift circles:** Sets how many circles are required to calculate the position drift.
- **Compass assistant:** Is a special symbol that appears on the display and helps to keep flight parameters (speed and direction) stable during calculation.

### 2.2.11.3 Manual wind settings

- Set manually - manual wind speed and direction can be set which will be displayed and used for all calculations.

### 2.2.11.4 Influence of wind in final glide

The actual wind data (speed and direction) influences the final glide calculation. In task mode the final glide indication is based on the remaining distance over all TPs until the finish (not over turn points already overflown). Wind influence for individual legs is based on actual wind data. Using the Head/Tail method will define wind direction on actual track being flown and this value will be taken into final glide calculation.



## Task

### 2.2.12 Task

The Task menu allows the setting of default zones for quicker and easier task creation.

Under **Other settings** can be set:

- TDT calculation sets the task delta time calculation method
- AAT calculation sets whether the next TP is set automatically or by hand
- Task start navigation sets the point to which your glider computer will navigate
- Sync with TP navigation sets the same turnpoint for Task and TP menu

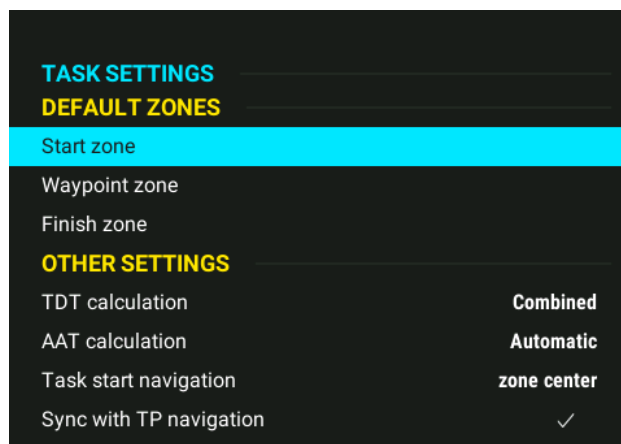



### 2.2.13 User interface

#### User interface

settings are saved to currently selected pilot profile.

In the User interface menu, the pilot can adjust most of the graphic options apart from layout, which has its own menu. All

#### 2.2.13.1 Map settings

All settings regarding map appearance (map palette colours, glider image, orientation, distance circles etc.) can be adjusted in the Map settings menu.

The pilot can select the zoom level used once circling has been detected under the field **At circling switch to**.

#### Map palette

The Map palette menu is used for adjusting colour schemes used for terrain display on the map.

Personal colour schemes can be created.

The last option allows the disabling of map appearance features, which is useful in situations when only airspace and task data is required.

The map can be temporarily disabled under shortcuts (long press on Zoom rotary knob).

#### Glider image

Glider image icon can be sized and coloured by choice.

Default:

- Colour white
- Size 25 (maximum size can be 60)

#### Map Orientation

The map orientation of LX Zeus can be used in three different ways:

- Track up: Glider always points to the top of the screen
- North up: North is always on the top of the screen
- Track circ. North: Combination of track up and north up related to flight status (circling, straight flight)

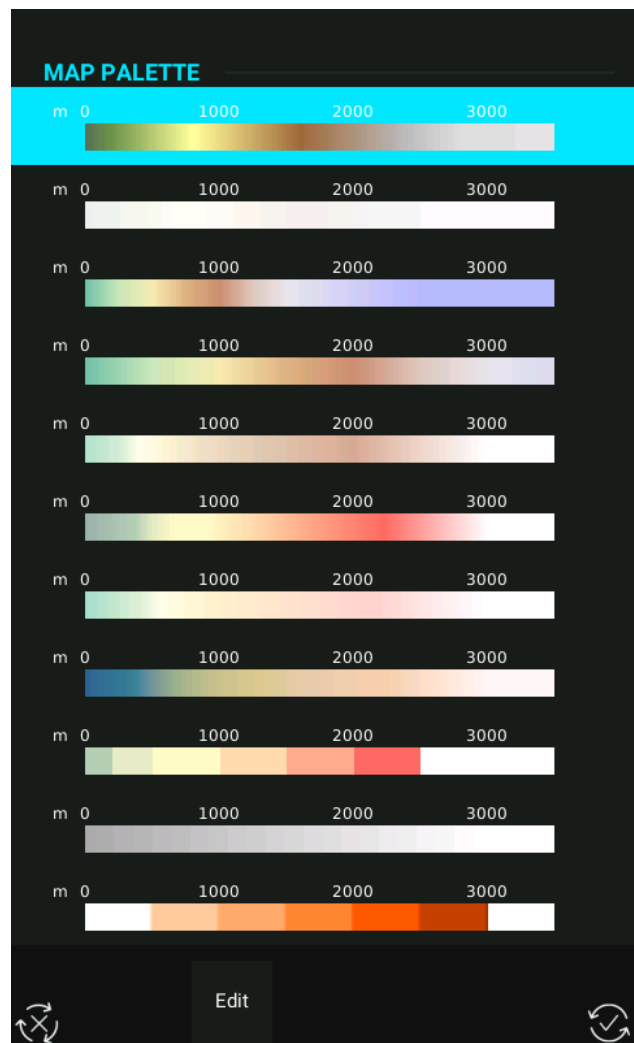
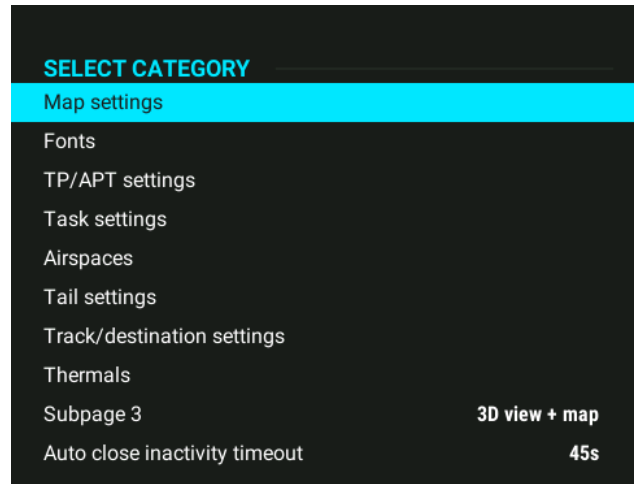

### Distance circles

In this section, it is possible to select the number, size and colour of distance circles on the map. Distance circles are a useful tool for getting a feel about the distance to certain objects on the map.

### Range (graphic glide reach)

Activating this feature shows the glide range curve from the current position in all directions. It uses wind, terrain and glider data to calculate the end result.

**Show range from zoom** defines from which zoom level the glide range is available. (If set on Never - function will be inactive)

Next three settings are connected to **fill colour**, **outline colour** and **outline width**.

**Note:** Range is displayed only in TP and APT view.

Range is calculated and displayed by using the following parameters:

- Reserve altitude
- Glider polar
- MC
- Ballast
- Bugs
- Elevation
- Wind

#### 2.2.13.2 Fonts

The font system is fully adjustable:

- Cities on map (default 15px)  
If this is set to 0px, there will be no city names on the map
- Turnpoint on map (default 15px)
- Airports on map (default 15px)
- Flarm objects on map (default 17px)
- Distance circles on map (15px)
- NavBox line (default 30px)
- Header (default 24px)

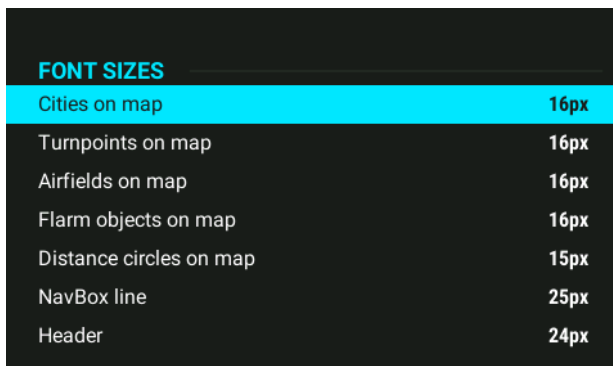
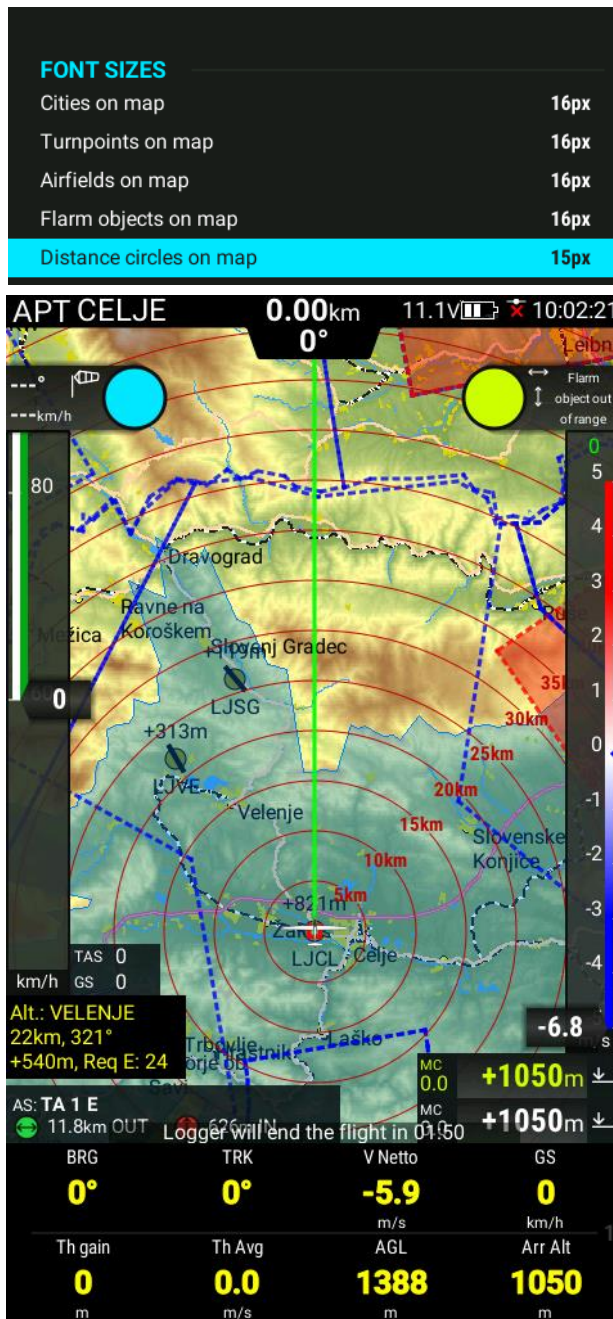



### 2.2.13.3 TP/APT settings

In this menu, the appearance and length of TP and APT labels on the map can be adjusted at different zoom levels:

- **Show TP till zoom:** Adjust visibility of TP at given zoom
- **Show TP labels till zoom:** Adjust visibility of TP labels at given zoom
- **TP labels length:** Set number of label characters shown on the map
- **TP label colour:** Select label colour
- **Hide turn-points near APT**
- **Draw specialized icons**
- **Specialized icons size**
- **Show APT till zoom:** Adjust visibility of APT at given zoom
- **Show APT labels till zoom:** Adjust visibility of APT labels at given zoom
- **APT labels length:** Adjust the number of label characters shown on the map, ICAO code can be selected
- **APT label colour:** Select label colour

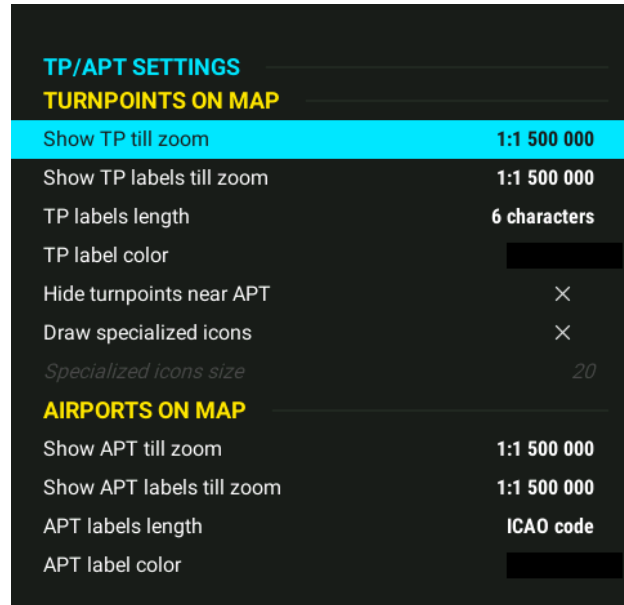

### 2.2.13.4 Task settings

This menu is used for personalizing start, finish and turn-point lines/zones. It is also possible to change their outline colours, fills and outline widths.

Show equidistant lines is a neat feature which enables the pilot to know in which direction no speed is being gained in an AAT zone. It is always best to fly perpendicular to the lines.

Default task colours:

- Active zone: Pink
- Active start/finish line: Red
- Inactive zone: Cyan
- Inactive start/finish line: Teal
- Legs yet to cover: Royal blue
- Active leg: Yellow
- Covered leg: Green
- Course to next TP: Cyan

Transparency can be set for all colours.

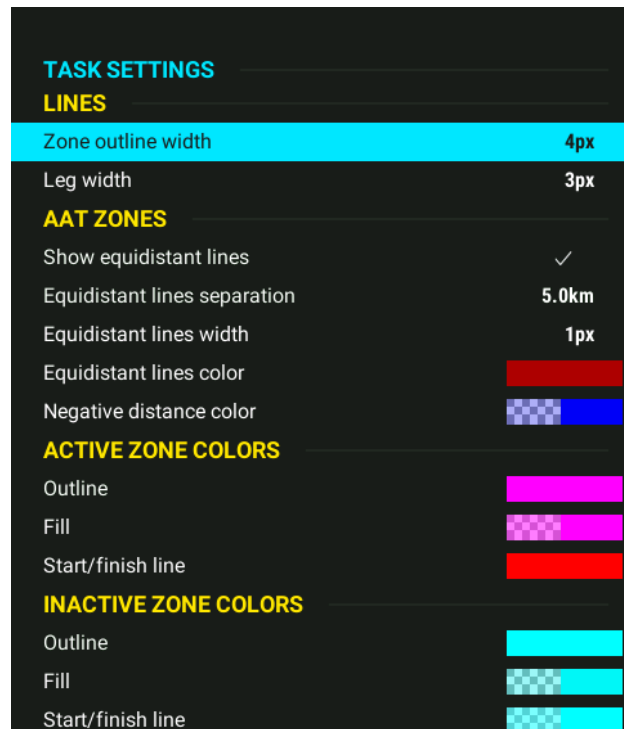

### 2.2.13.5 Airspace

The colours and width of airspace sections to meet personal preferences can be set.

Default colours are:

- Selected/active airspace: Blue
- Controlled area: Red
- Prohibited area: Red
- All other: Blue

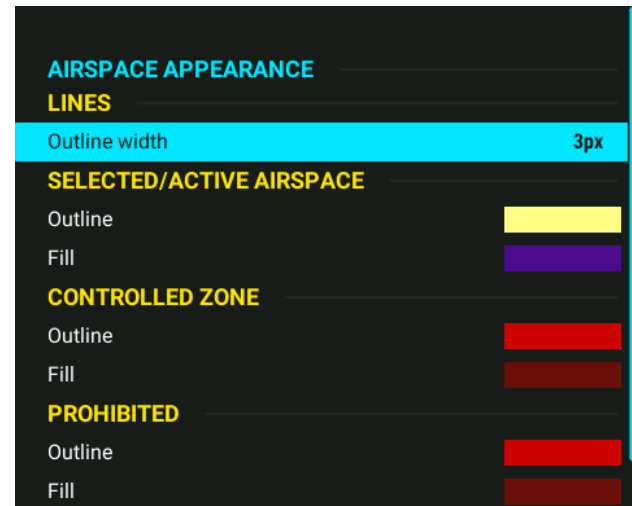

### 2.2.13.6 Tail settings

This page is used for adjusting the tail parameters.

**Draw tail for last** setting is used for determining how long the tail should be.

**Vario colour-coding** setting allows the pilot to enable or disable colour-coding. If this function is disabled, it is still possible to choose the colour for the tail.

**ENL** colour is displayed when the flight recorder detects the engine is running.

If a grey (default colour) line as the tail is seen, and the engine is not running, please check that the flight recorder is not positioned in such a way that the noise from ventilation or an open window is not causing the issue.

Default vario tail colours are:

- Negative: Blue
- Zero: White
- Positive: Red
- ENL: Dark grey

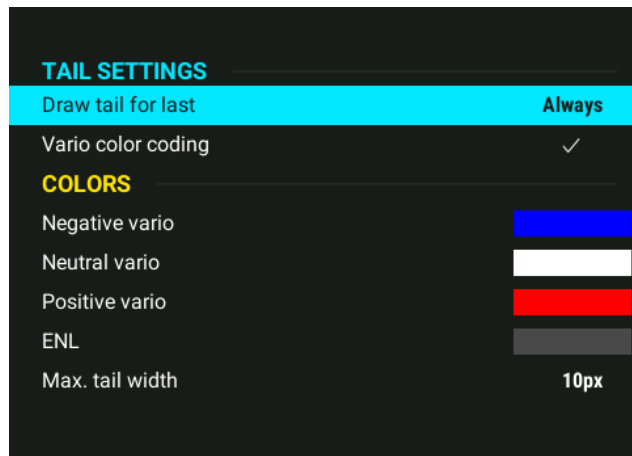

The width of the tail depends on the strength of the thermal in that moment.

The stronger the thermal, the wider the tail. The default tail width is 10px (2 pixels per 1m/s)

### 2.2.13.7 Track/destination settings

- Track colour shows the vector of current movement. The default colour is green. It can be changed by setting the transparency to 100%.
- Track to destination colour page sets the colour of the vector line that connects the glider with the destination point. Default track colour is Cyan.

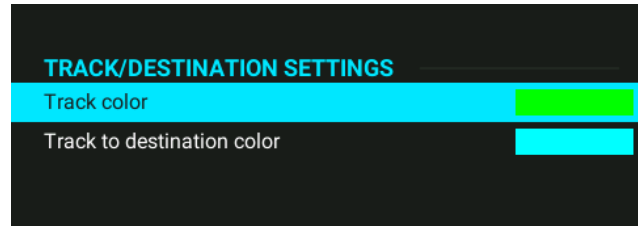

### 2.2.13.8 Thermals

This page is used for setting the thermal icon parameters. The Thermal icon will show where the glider has circled and what the average thermal strength was.

The Zoom level can be selected for showing at which it will show the colour coding as well as the minimum avg. vario strength and minimum altitude gained so it doesn't show every turn.

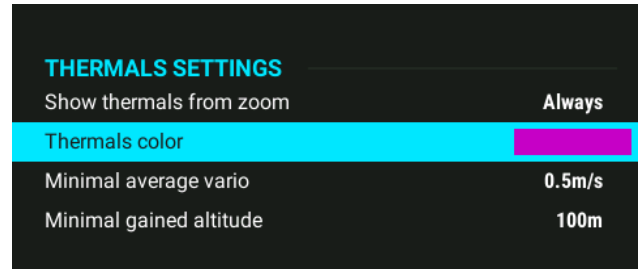

### 2.2.13.9 Subpage 3

Subpage number 3 can be enabled or disabled.

It can set so that it only shows a 3D view or a 3D view + map.

### 2.2.13.10 Auto close inactivity time out

LX Zeus monitors the push buttons and rotary knobs during the editing process. If no action is detected the program will change back to the previously used navigation page after a predefined time period. The time is flexible and can be chosen in a range from 6 to 60 seconds. It is also possible to disable the auto close function. If the time is set to off, than the page will disappear only if the Volume rotary knob is pressed ("escape" / "go back" button). The default time is 30 seconds.



2.2.13.11 Layout

Layout

The LX Zeus home screen can be customised. Which NavBoxes are shown can be changed as well as their size, order and where they are placed. The same can be done with the map as well as other indicators.

2.2.13.12 Layout edit procedure:

- Go to setup / **Layout**
- Press **Zoom** rotary knob on Layout
- **Check** which panels are to be edited (TP, APT, TSK)
- Rotate zoom rotary knob to select **Edit** and **press Zoom rotary knob.**
- Press the **Edit layout** button
- Main screen will open with a blue frame (blue frame shows what has been selected, eg: map, NavBox container or another indicator)
- **Select the indicator, NavBox container or map** to be edited by **rotating** the Zoom rotary knob (the current selection will be displayed with a frame around the selected indicator)

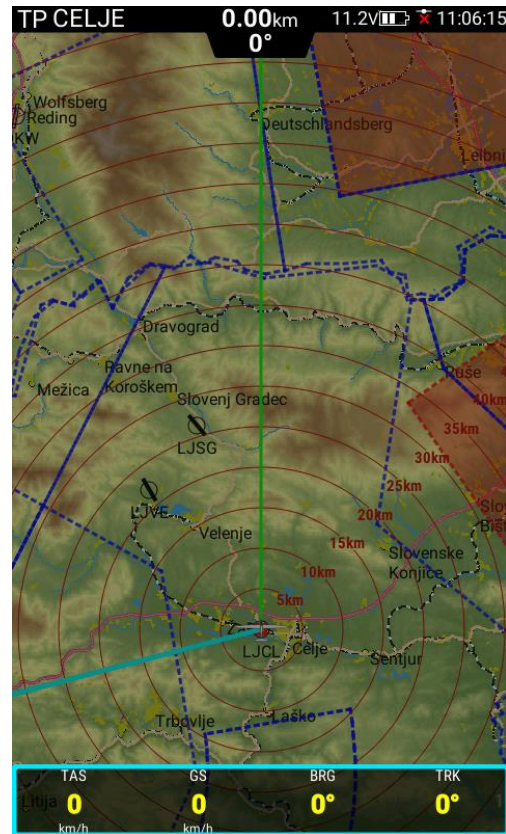
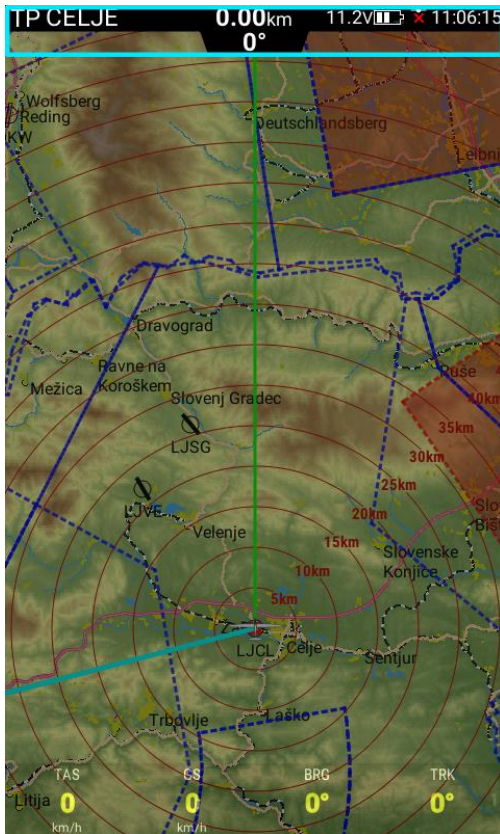
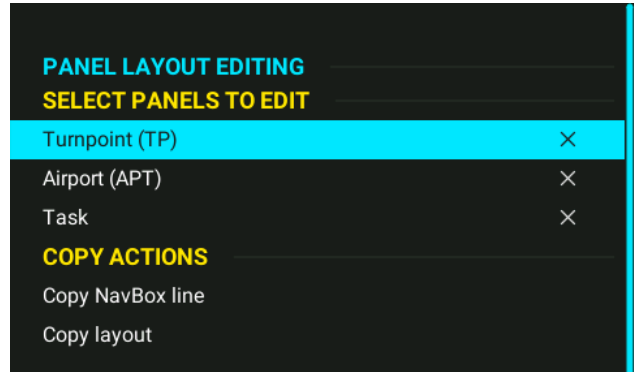

## Moving and resizing

### How to move selected element:

- **Select** indicator to be moved
- **Short press Zoom rotary knob** (a large cursor symbol will appear in the middle of the indicator)
- Use **Zoom** and **Volume** rotary knob to move the indicator
- Press Zoom rotary knob to stop the move procedure and start the resize procedure

### How to resize (expand or compress):

- **Next press** the Zoom rotary knob and it will open a similar window but now with a **cross** through the selected indicator.
- Use **Zoom** and **Volume** rotary knobs to resize it.
- Press Zoom rotary knob to stop the resizing process.

The customisation process terminates when the Volume rotary knob is pressed.

(**layout saved** message will appear)

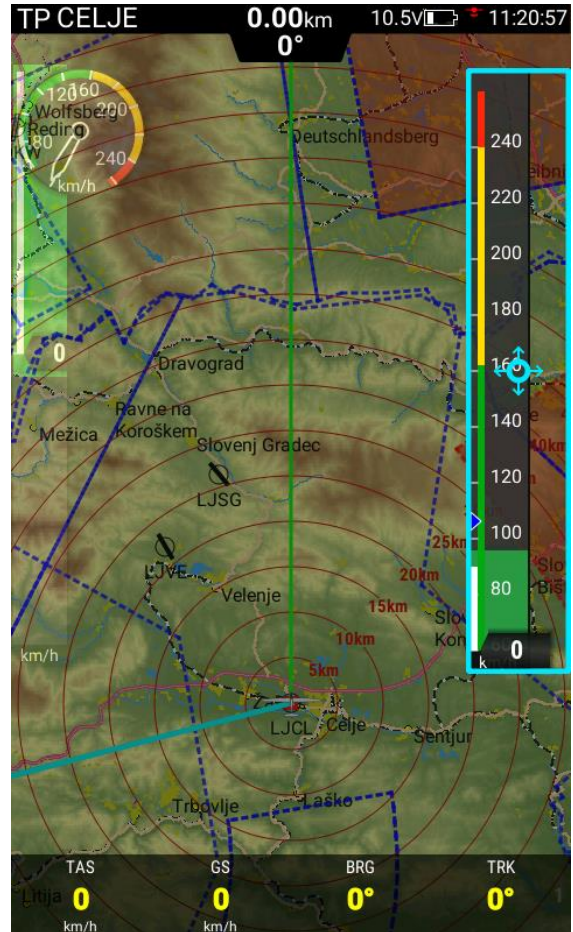

### Note!

After saving the new layout it may appear that nothing changed on the screen, this is because you are at the wrong navigation screen (if you changed the TP and you are in the APT screen then it seems that nothing has changed). Press an APT button to select the customized screen.

### 2.2.13.12.1 Selecting/Deselecting and editing

#### Editing process:

- Select the indicator to be customized (a blue frame will appear).
- **LONG** press the **Zoom** rotary knob (if a long press is not made then there will still be an option to move or resize it)
- Select the colour to be changed (rotate Zoom rotary knob) and give a **SHORT** press of the **Zoom rotary knob** - a new window (Edit Background colour) will open
- Now the colour can be changed simply by picking one from the palette and **pressing the Zoom rotary knob**. If one has been picked from the palette, but transparency is required, just go back again. Edit Background colour window (**press Zoom**) and go to transparency (**press Zoom**) and go to transparency (**press Zoom**)

Rotate Zoom rotary knob to set the transparency required, confirm it by **pressing Zoom rotary knob** and then **pressing Volume** to escape.

- To terminate the customization process, **press the Volume** rotary knob once to escape from Edit Background menu and then again **press the Volume rotary knob** to escape from Properties/Actions menu. An edited indicator will appear on the screen that you have customized

#### **Note!**

To escape from Edit Background colour menu you don't necessarily have to press **Volume rotary knob**, you can simply wait 15 seconds and the screen will go back to the first (Properties/actions) menu.

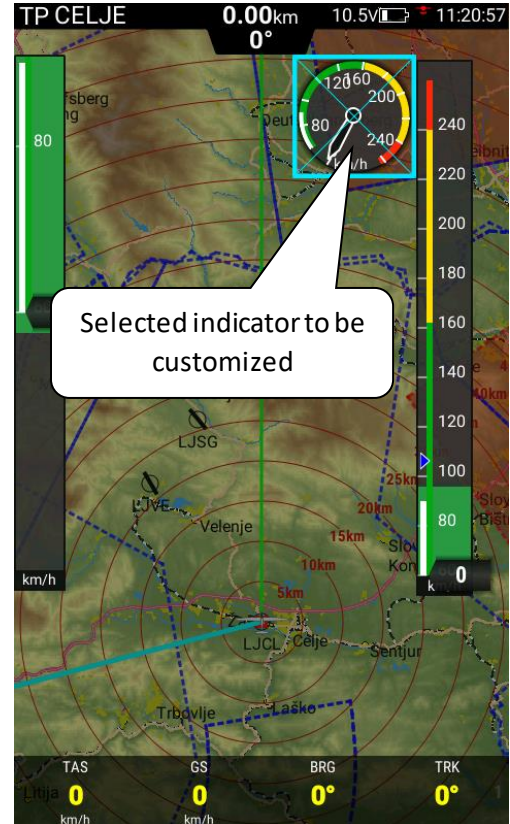

Changing the background colour of indicators



**Selecting/deselecting process:**

- Go to Setup > Layout, press Zoom rotary knob, select the screen to be edited and go to Edit (press Zoom rotary knob)
- Make a LONG press on Zoom rotary knob and the window Properties/Actions will open
- **Edit flight map properties**
- Select row: **Select Indicators** and press Zoom rotary knob and a window **Select indicators for chosen panels** will open
- Now select/deselect indicators that are not wanted on the screen. Select and deselect them by rotating and pressing the Zoom rotary knob
- To get out of edit mode, press Volume rotary knob and the selected indicator will appear on the screen

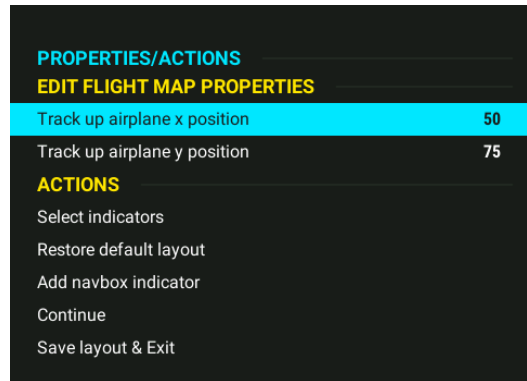

Selected Header indicator

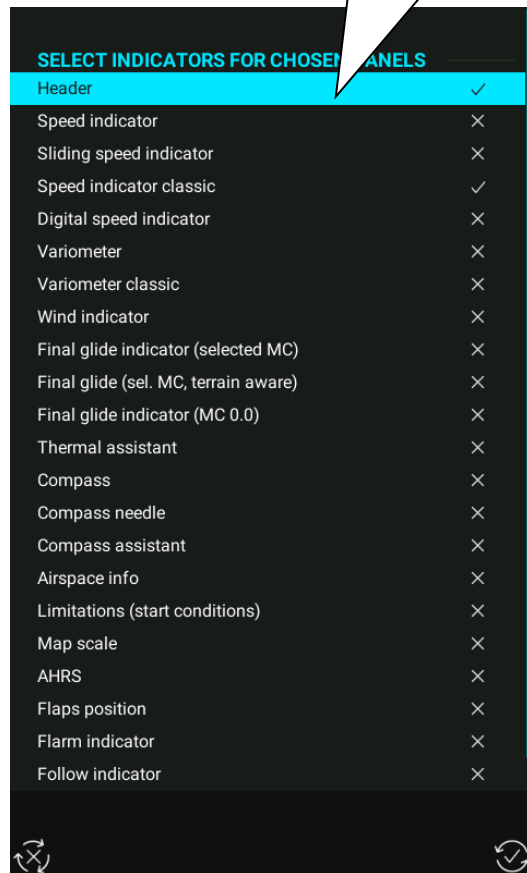

### Properties/Actions window

This window is activated by a LONG press of the Zoom rotary knob. In this window, colours can be adjusted for the selected indicator as well as other setting such as:

- Number of rows for NavBox container
- Scale size for Sliding speed indicator

By selecting one of the **Action** rows one can:

- Select indicators to be seen on the screen
- Restore the layout to default settings
- Continue with editing indicators
- Save layout and exit with new settings

**Map and NavBox container  
are not indicators.**

### Indicators

The following indicators can be selected:

- Header – upper row
- Speed indicator – IAS
- Sliding speed indicator – not the whole IAS – the scale that is displayed can be customised
- Classic (circular) speed indicator
- Variometer – sliding variometer
- Variometer classic – rounded variometer
- Wind indicator – shows direction and speed
- Final glide indicator (selected MC)
- Final glide indicator (MC 0.0)
- Thermal assistant
- Compass – rounded compass
- Compass needle
- Compass assistant
- Airspace info
- Limitations (start conditions)
- Map scale
- AHRS
- Flap position
- Flarm indicator
- Best alternate APT info

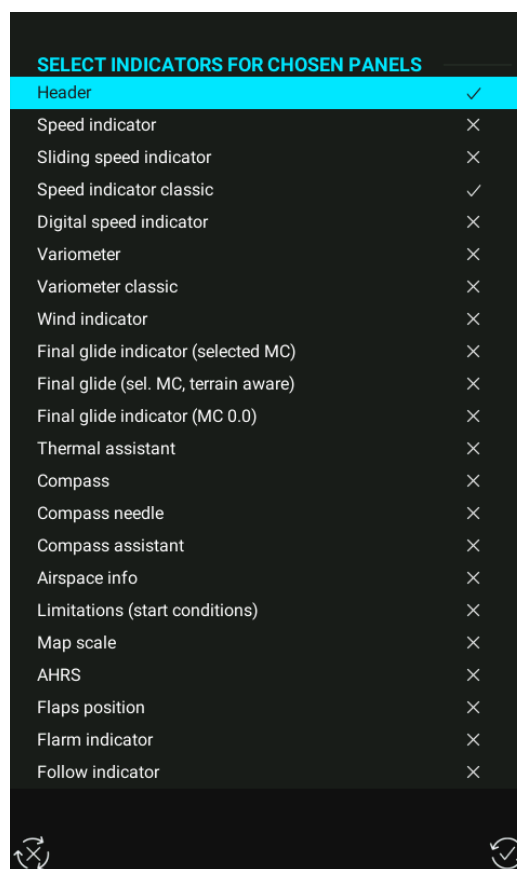
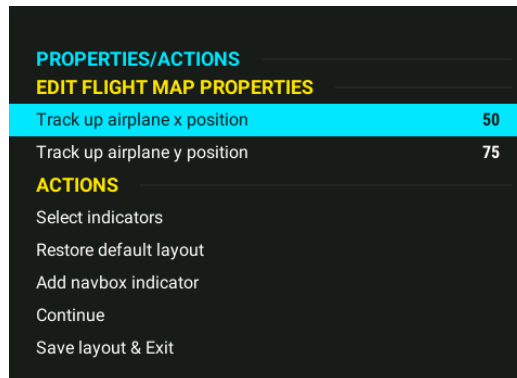

**Note!**  
Restore to default will  
restore back to factory  
settings.



## Map – NavBox container transparency

If it is required to have a NavBox container transparent, then **the map should be stretched over the whole screen** and background colour for the NavBox container should be set to transparent.

### 2.2.13.13 Copy NavBoxes

The whole NavBox container can be copied from one panel to another (TP/APT/TSK) via Layout. Always prepare NavBoxes on one panel to be used as a reference for other panels. Once a reference panel is selected, should check the destination panels into which NavBoxes are to be copied. After that, select Copy from `reference` to `destination` to complete the procedure.

### 2.2.13.14 Copy layout

Copy of one layout can be copied to one or both remaining screens.

Under **Reference panel** choose the layout to be copied. Under **Destination panels** choose which layout to copy the reference layout to. After selection press **Copy from reference to destination** to complete the procedure. A green message will appear to confirm that the layout was successfully copied and saved.

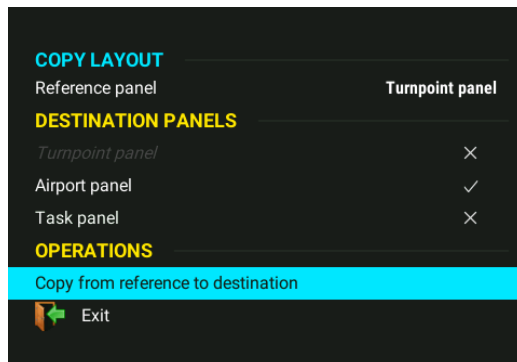

### 2.2.13.15 NavBoxes indicator

A NavBox as an indicator can be added to the map. There is no limitation on the quantity of NavBox indicators on the map. Each NavBox can be customized (different colour, transparency, size, position).

Procedure for adding new NavBox indicators:

- Go to Layout and select the screen to be adjusted, press EDIT
- A long press on Zoom rotary knob will open the Properties/Actions window
- Move down to “Add NavBox indicator” and select this line with a short press on the Zoom rotary knob
- A list of all available NavBoxes will appear. Select the NavBox required and position it on the map in the same way as moving/resizing other indicators

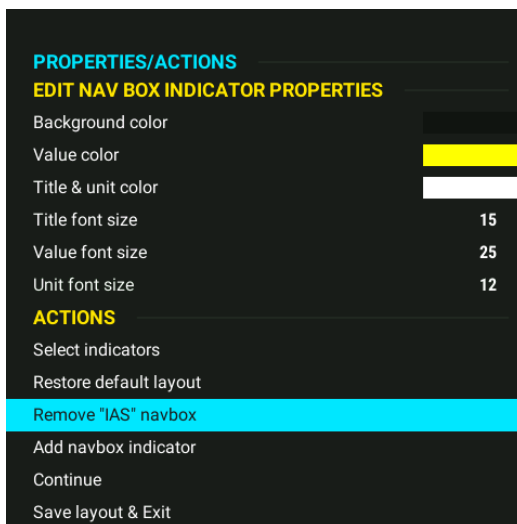

Procedure for removing NavBox indicators:

- Go to Layout and select the screen to be adjusted, press EDIT
- A long press on the Zoom rotary knob will open a Properties/Actions window
- Select “Remove “xy” NavBox”

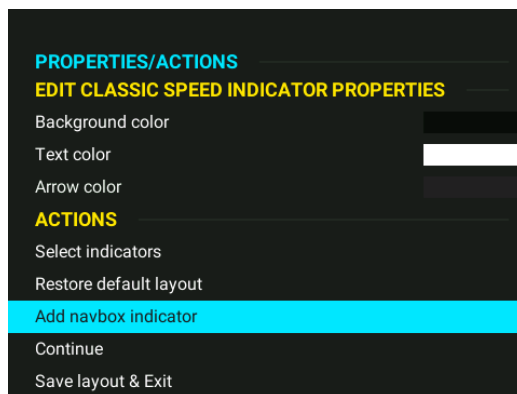

## 2.3 System Setup

The parameters set in this section are valid for all pilots (and are not saved to a specific user profile).



### 2.3.1 Units

A large selection of units can be defined in this menu.

Units can be defined for: Altitude, Vario (rate of climb), Speed, Task speed, Wind speed, Distance, Pressure, Temperature, and Mass.

Pre-set metric, imperial or UK units can be set.

UNIT SETTINGS	
<b>VERTICAL UNITS</b>	
Altitude	meter(m)
Vario	m/s
<b>HORIZONTAL UNITS</b>	
Speed	km/h
Task speed	km/h
Wind speed	km/h
Distance	kilometer(km)
<b>OTHER UNITS</b>	
Pressure	hPa
Temperature	°C
Mass	kilogram(kg)



### 2.3.2 Glider

Nearly all glider polars are stored in the LX Zeus memory. In addition to these standard polars it is possible to create custom polars by changing the parameters.

In the glider menu, it is possible to set all glider related information, such as:

- Competition ID
- Equipment weight
- Active Polar
- Speed indicator settings
- Flap position settings
- TE level (not possible from second seat unit)
- TE filter
- Registration number

GLIDER SETTINGS	
<b>Competition</b>	
Registration	
Equipment weight	0kg
Active Polar	Antares 23T
Speed indicator settings	
Flaps position settings	
TE level	0%
TE filter	4

EDIT GLIDER	
<b>ACTIVE GLIDER</b>	
Active polar	
<b>EDIT GLIDER</b>	
Select glider	User defined
Glider name	
<b>POLAR PARAMETERS</b>	
A	0.90
B	-1.29
C	0.86
<b>GLIDER PARAMETERS</b>	
Empty mass	510kg
Reference mass	500kg
Maximal mass	850kg
Wing area	14.8m <sup>2</sup>
DAeC index	125

### 2.3.2.1 Creating a user defined polar

In Setup > Glider select Active polar. Enter the required polar parameters.

A, B, C parameters can be calculated the LXe PC program, or the built-in calculator described below can be used.

#### Calculating A, B and C constants

To calculate A, B and C parameters, follow these steps:

- Setup > Glider Active polar > Select glider > User defined.
- Now press the Calc. A, B, C button. Then enter Tobtained from the glider polar or from other data sources. Be aware that the most important parameter is reference weight. For different reference weights the numbers will differ.
- To use these parameters select Use calculated parameters.

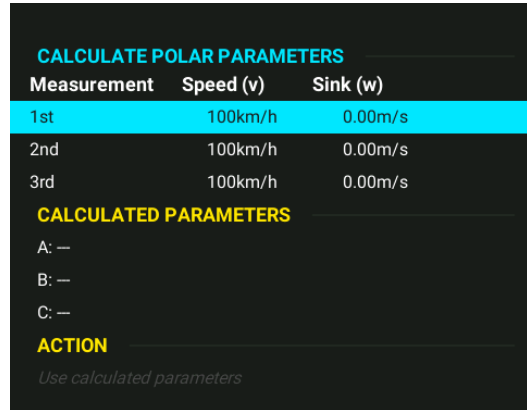

3 default polars can be set under Active polar which will appear once the Zeus is turned on. This feature is especially useful for a glider with variable wing span.

### 2.3.2.2 Speed indicator settings

The speed markings of the sliding IAS indicator colours on the Zeus can be adjusted.

### 2.3.2.3 Flaps position settings

For gliders with flaps, Zeus offers an indicator that will remind the pilot to change flaps to the recommended position. The speeds and position numbers must be defined. Recommended flaps position is available as an indicator in Layout (Flap position indicator) or as a NavBox (Recommended flap position). If a Flaps sensor is connected to the CAN bus then please check the calibration procedure below. Using sensors enables the current flap position to be shown alongside the recommended position. This information is available as an Indicator, NavBox and on a stand-alone LX NavBox device connected to the CAN bus.

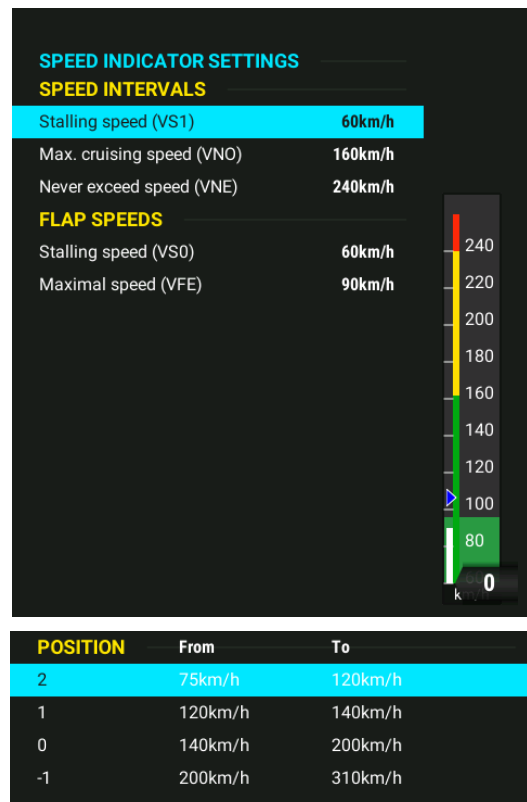

### 2.3.2.4 Flap sensor calibration

If a LX Flap Sensor is connected to the CAN bus it is possible to show the current flap position together with the recommended flap position. Connect the LX CANAD to the CAN bus and insert two wires from the flap sensor to LX CANAD inputs (recommended is IN1). Open the Flaps position settings dialog on LX Zeus. First select the channel where the Flap sensor is connected to LX CANAD (default is IN1). Next move the Flap lever and check that Lever position changes values; this means that the Flap sensor has been properly connected to the system. Now the calibration procedure can be commenced:

- Put the flap lever to aft position (landing or most positive).
- With Zoom rotary knob select the first line.
- Start editing this line:
  - o Insert position name (up to 4 characters).
  - o Select minimum speed for this flap position.
  - o Select maximum speed for this flap position.
  - o Press Save screen button to save settings for this line.
- Move the lever to next position and repeat procedure until all positions have been covered.
- Exit this dialog to send the new settings to LX Flaps Sensor.

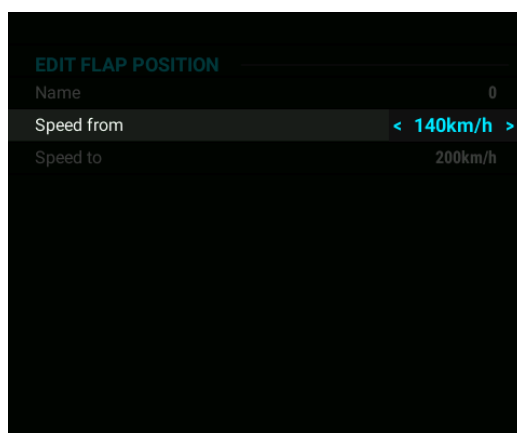
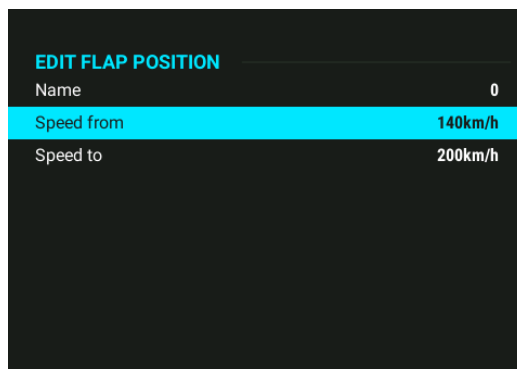

### 2.3.2.5 Total Energy (TE) level and filter

There are 2 ways of providing TE for the LX Zeus; either tube or electronic compensation.

- **TE level\*\*\***, set TE compensation style, 0% for TE tube compensation.
- **TE filter\*\*\***, only valid for electronic TE compensation.

The LX system incorporates a configurable electronic filter. This filter adjusts the time constant and is adjustable between 0.2 and 5 seconds. The 0.2 setting is the fastest while the 5 setting provides maximum damping.

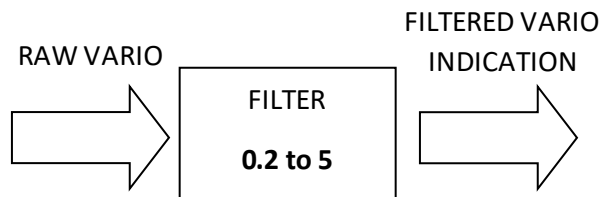

In more detail:

### Pneumatic compensation

The method used is determined by the % figure set for compensation as well as the way in which the pneumatic tubes are connected. If compensation by **using a TE probe** is required, then set the % figure at 0%. With this method, the Zeus will not process any electronic compensation and will use only the TE source.

When using pneumatic compensation using a TE probe, the accuracy of the TE compensation depends entirely on the location, size and quality of the TE tube. The installation must be leak-proof.

**Note!**

Electronic and pneumatic TE compensation requires different tube connections.

### Electronic TE compensation

Electronic TE compensation is activated when a % setting of more than zero is selected. When this is done a software routine is activated and the system will provide TE compensation. The default value is 100% but this can be adjusted by test flying and fine tuning the setting to deliver the optimum compensation.

Electronic TE compensation can be fine-tuned during flight using the procedure set out below. *It is essential that this is only done in smooth air as it is not possible to tune the TE accurately when there is a lot of thermal activity.*

- Select 100 % and default **TEF (TE filter)**.
- Accelerate up to approximately 160 km/h (75 kts) and keep the speed stable for a few seconds.
- Gently reduce the speed to 80 km/h (45 kts).

Observe the vario indicator during the manoeuvre. At 160 km/h (75 Knots) the vario will indicate about -2 m/s (-4kts). During the speed reduction, the vario should move towards zero and should never exceed zero (slightly positive indications are acceptable). If the vario shows a climb, then the compensation is too low, increase the TE%; and vice versa. Repeat this procedure and make further adjustments as necessary.

Electronic TE is only effective when the P<sub>tot</sub> and P<sub>static</sub> sources are co-located and the pneumatic lines to the instrument are approximately the same length. The best sensor to use is the combined P<sub>tot</sub>/P<sub>static</sub> Prandtl-type tube. If problems are experienced with the electronic TE compensation, then the most likely cause is the glider's static source. The static source can be checked by changing the connection of the pneumatic tubes for electronic compensation, and then setting the **TE**: to 0%. In still air, and as explained above, accelerate to approximately 160 km/h (75 Knots) and reduce the speed. Observe the vario indicator. If the static source is good, then the vario should immediately start to move showing a climb. If the needle initially shows increased sink and then moves to a climb, the static source of the glider is unsuitable and there is no way to provide successful TE compensation electronically. The use of a dedicated and accurate fin mounted P<sub>tot</sub>/P<sub>static</sub> source, such as a Prandtl tube, will be the only solution in such cases.

**Note!**

If electronic TE compensation is selected, then the TE (Pst) port should be connected to a good static pressure source. If pneumatic compensation is selected, then the TE (Pst) port should be connected to the TE probe.

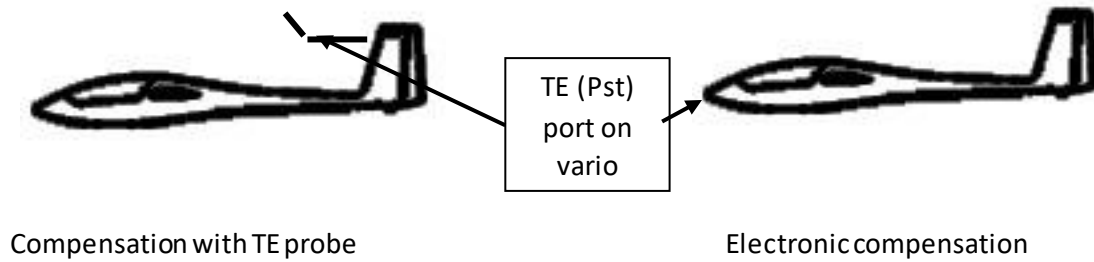

**Note!**

Check LX Eos user manual for proper installation.

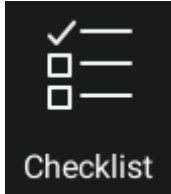

### 2.3.3 Checklist

Checklists are available under Setup > Checklist or by a long press of the SUBP button.

Once a checklist is open, keep pressing the Zoom rotary knob to complete the written actions as per the checklist.

To create a new checklist, go to the Checklist menu and click New. After writing the checklist name, choose the Edit button to edit name or Edit list to write the list itself.

A checklist can also be created on a computer which should be quicker. It can be imported via USB key to the LX Zeus. To import/export a checklist go to Setup > Transfer > Checklist. Use **Check list editor software for LX Zeus** available free on [www.lxnavigation.com](http://www.lxnavigation.com) under the software section.

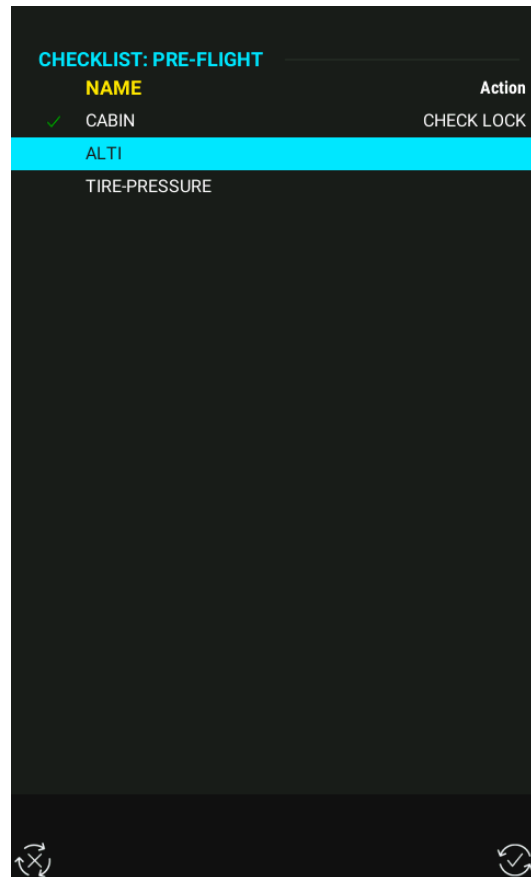
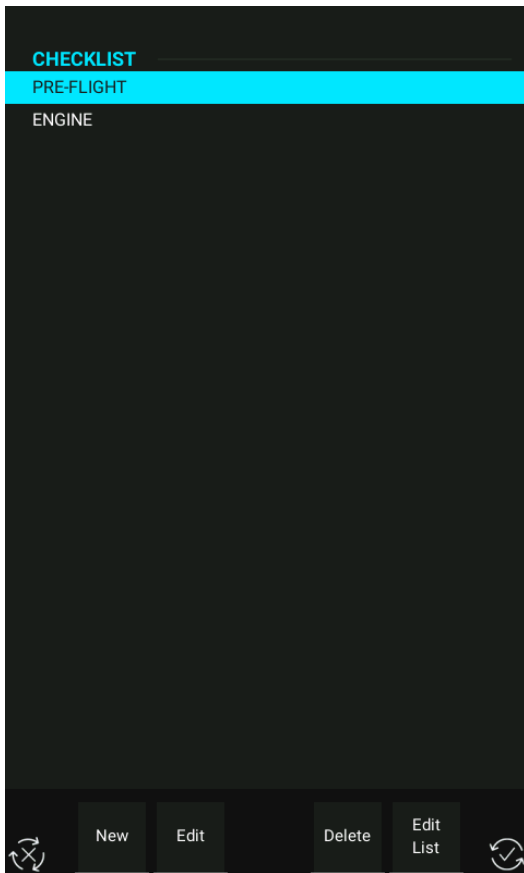

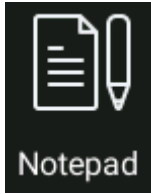

### 2.3.4 Notepad

In the Notepad menu, a bespoke .txt file with whatever content is required can be prepared. Checklists, notes, input frequencies etc. can all be included

.txt files can be uploaded with the USB stick by pressing the screen button LOAD (button SELECT/NEAR). Notes can be also written directly into the LX Zeus by using the Zoom and Volume rotary knobs.

- Screen button MODE is used to change between uppercase letters, lowercase letters, numbers, symbols, navigate etc.
- Using NAVIGATE enables moving the text by using both rotary switches. Characters can be deleted by pressing the Volume rotary knob. To confirm the written text, press mode, change to symbols, find enter symbol and then confirm it by pressing Zoom rotary knob.
- Screen button METHOD is used to change between `replace` and `insert` characters into the written text.
- Copy to USB is used to copy a current note to USB stick and the file will appear on the stick in .txt format.
- Load is to upload .txt file from USB stick.
- Save & Exit – is used to save the current notes and also exit back to the setup menu.

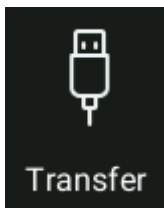
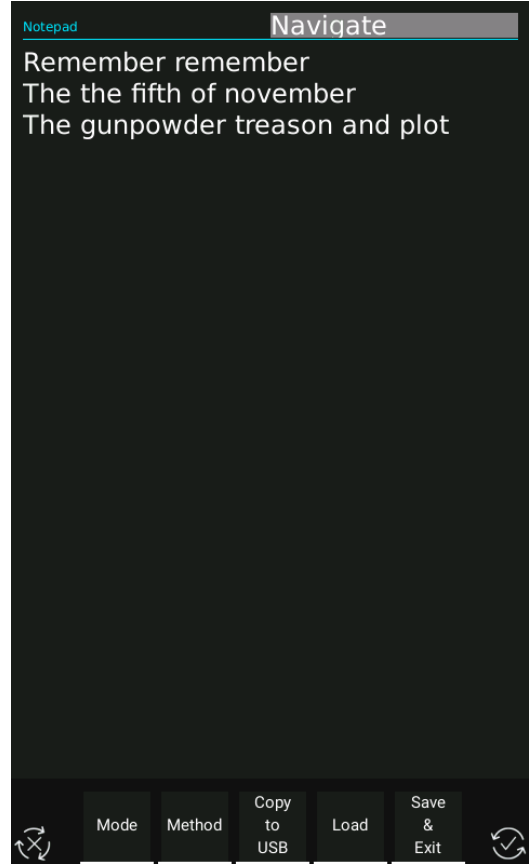

### 2.3.5 Transfer

The only way to transfer data from and to LX Zeus is via USB stick. Any regular regular USB stick formatted in FAT file system format can be used. One such USB stick is delivered with each LX Zeus and is already formatted. (use a slim USB stick for LX Zeus 2.8). After selecting the item of interest, by a press on the Zoom rotary knob, the procedure will start.

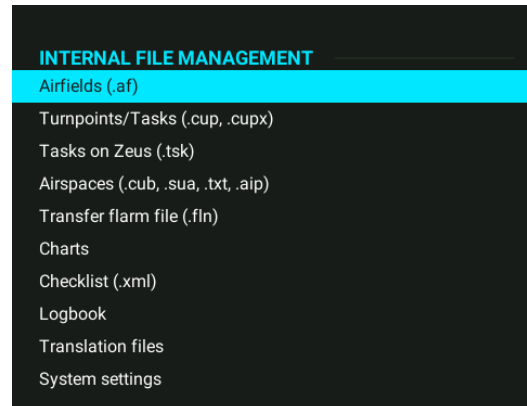



**The transfer procedure is as follows:**

- Insert USB stick
- Press SETUP button
- Select Transfer
- Press Zoom rotary knob
- Select what is to be transferred (example airfields), and press Zoom rotary knob
- Select “transfer file from USB” and press the Zoom rotary knob
- Example: all .af files stored on the USB stick will be shown
- Select the **file of interest** and press on the Zoom rotary knob
- The transfer will follow and a window and a **green check** will show
- Go to **Select**, press Zoom rotary knob and select the file
- The file is now activated (green check at select row)

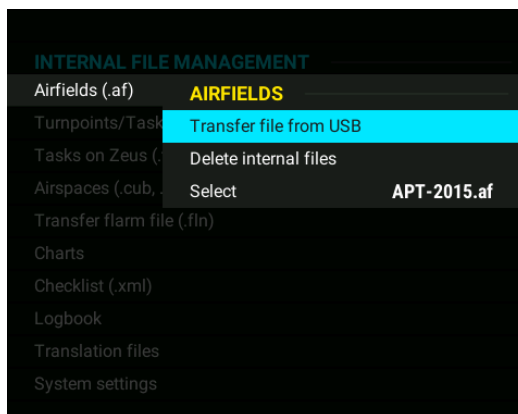

**Important!**

Only one .af file can be active at a time. After the transfer has finished you should **activate** using **Select** function. A green check means the file is active.

**How to delete files (APT, TP, AS):**

Files can be removed from the LX Zeus using the **Delete internal files** command. The command is executable for Airports, Turn points and Airspace.

*2.3.5.1 Transfer Airport data*

The airport database in .af format for the Zeus is at webpage [www.lxnavigation.com](http://www.lxnavigation.com). It is free of charge with no code required.

*2.3.5.2 Transfer Turnpoint data*

The turnpoint data should be included in a file with extension **.cup** or **.cupx**.

Three TP files can be active at the same time. Turn-points of any of the three files will be available for navigation without any limitations.

**Transfer specific tasks**

Tasks can be uploaded to Zeus via a USB key.

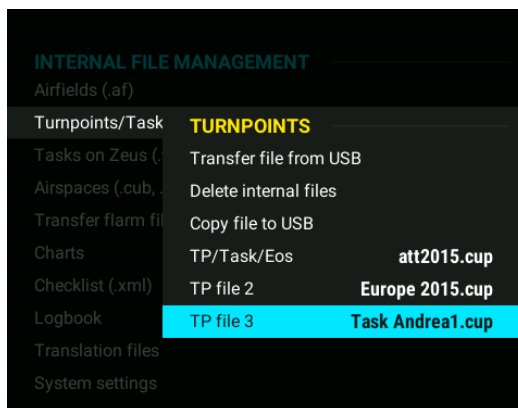

**Note!**

The first TP file is also called TASK file, which means, if you want to import tasks from file, that you have to select your file at **TP/Task/Eos**. This file is also sent to LX Eos. In backup mode, you can use points from this file to navigate. Note that only the first 1000 points are sent to LX Eos.

To transfer a specific task, follow these steps:

- **Export:**
  - Insert USB stick
  - Press TSK button and select Save to USB. This will save the task which is active in **.cup** format, together with turn-points used in this tasks
  - Remove USB stick
- **Import:**
  - Insert USB stick
  - Press SETUP button and go to Transfer
  - Go to Turn-points/Tasks (.cup, .cupx)
  - Go to transfer file from USB
  - Select the intended task
  - Go to the TP/Task/Eos file window and activate the intended task

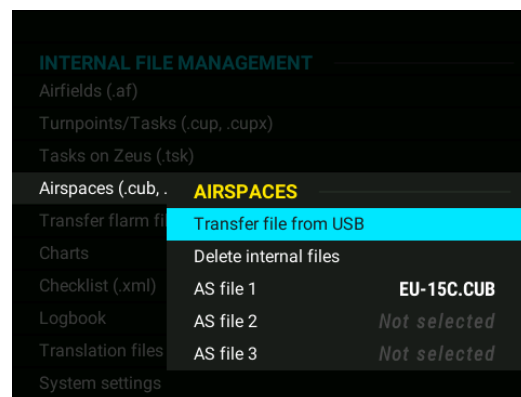
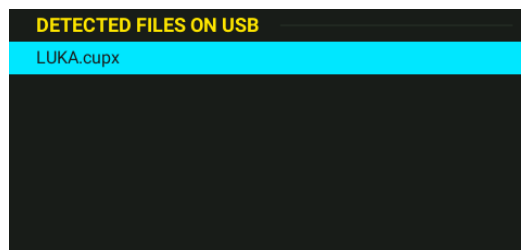

### Transfer all tasks

This is used to transfer all tasks from one LX Zeus to another LX Zeus device.

- **Export:**
  - Insert USB stick
  - Press SETUP button and go to Transfer
  - Go to Tasks on Zeus (.tsk)
  - Select Save all tasks to USB (this will save all tasks as one file in **.tsk** format)
  - Remove USB
- **Import**
  - Insert USB
  - Press SETUP button and go to Transfer
  - Go to task on Zeus (.tsk)
  - Select Copy all tasks from USB

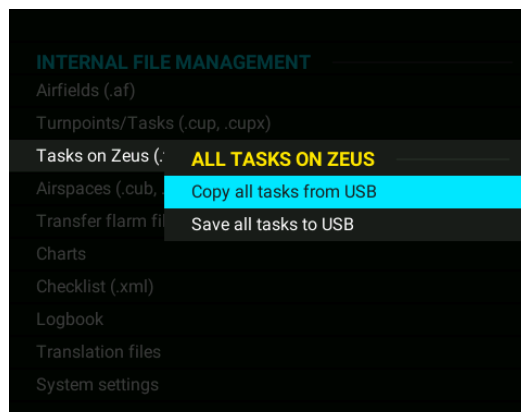

**This is valid only for Tasks made on LX Zeus, tasks made on SeeYou or Strepla have to be uploaded as TP (TP/Task file) using .cup format.**

### 2.3.5.3 Transfer Airspace files

To transfer airspace data, use the Airspace option in the Transfer menu. The files should be in **.cub**, **.sua** or **OpenTXT** format. The latest known airspace data is available free on [www.lxnavigation.com](http://www.lxnavigation.com). The airspace files normally cover the whole continent.

Three **airspace** sections can be active at the same time. Special event airspace, such as for competitions, can also be loaded.

### 2.3.5.4 Transfer Flarmnet files

Files with extension **.fln** include Flarm customized IDs and some added data about flarm objects which makes it possible to identify gliders in the vicinity with their original IDs (usually competition ID). The file is available on <http://www.flarmnet.org>

### 2.3.5.5 Transfer Charts

ICAO charts can also be used on the LX Zeus. The file for the charts has to be **.ras** format. The ICAO charts can be activated after importing a license file which must be purchased from LX Navigation. The license file should be transferred via USB stick.

A chart license can be transferred by going to Charts and selecting Transfer licence from USB. Current charts can be checked and deleted in the same window.

LX Navigation supports ICAO charts from Deutsche Flugsicherung and Rogers Data.

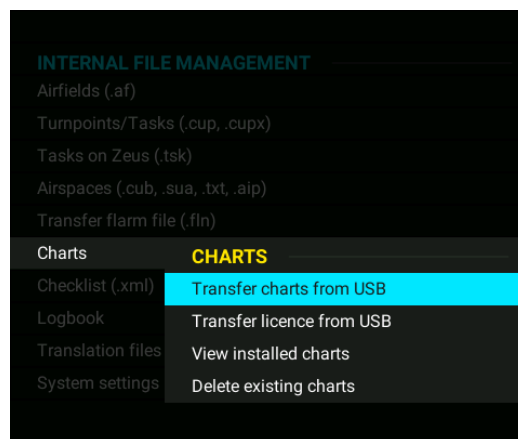

### 2.3.5.6 Transfer Checklist

Checklists can be prepared on a personal computer using the special PC software available free from the LX Navigation website. Files must be written in **.xml** format. They can be uploaded into LX Zeus by choosing Checklist (.xml) in this menu. It is also possible to transfer checklists from LX Zeus to USB.

### 2.3.5.7 Transfer Logbook

Flights can be transferred from the Logbook under the Statistics page or from this menu.

### 2.3.5.8 Transfer translation files

A file can be translated via special software from LX Navigation (free on request). Once a file is completed it can be transferred into LX Zeus using this menu.

### 2.3.5.9 System settings

This option should be used to transfer the complete system settings from one Zeus to another.

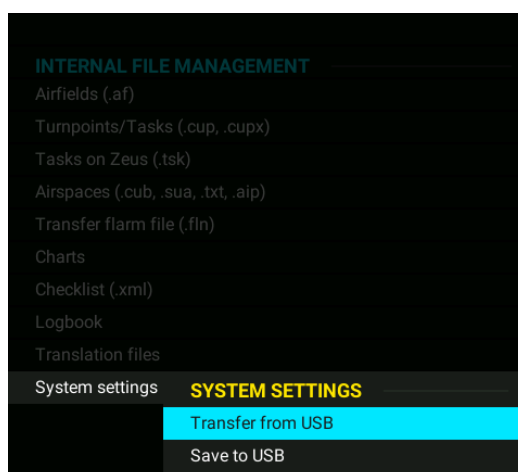

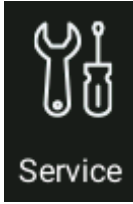

### 2.3.6 Service

Useful tools can be accessed under this section, such as:

- Compass calibration.
- Level adjustment of units with AHRS.
- Detected hardware.

With the use of **admin passwords**, the LX Zeus can be set back to factory settings with the password 46486. This will also delete all flights from Colibri II and Eos if they are connected to the system.

Useful passwords:

- Factory reset \_\_\_\_\_ 46486
- Grab image \_\_\_\_\_ 315
- Delete all flights \_\_\_\_\_ 99999
- AHRS disable \_\_\_\_\_ 2478
- Voltage offset \_\_\_\_\_ 8658
- Screen rotate \_\_\_\_\_ 9109
- Saving crash report \_\_\_\_\_ 27274
- Audio player on Eos \_\_\_\_\_ 28346

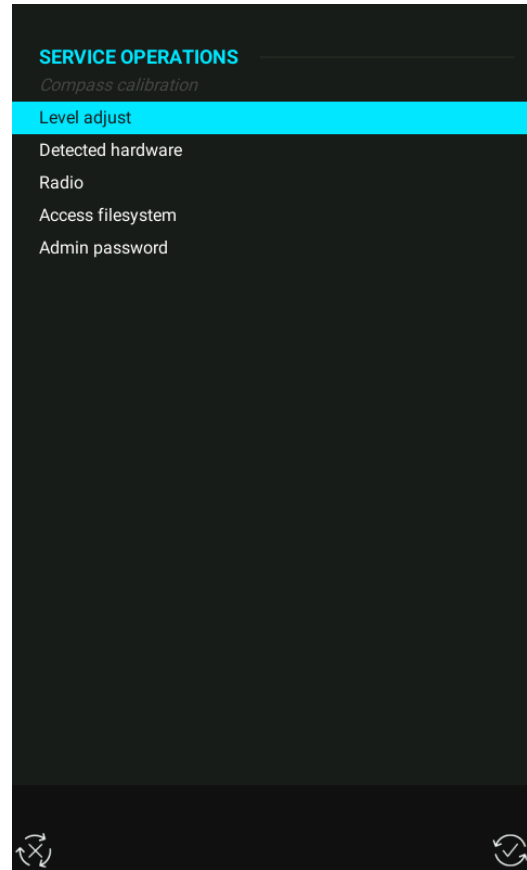

#### 2.3.6.1 Screen rotation

The screen can be rotated after inserting the correct password. When a password is entered a reboot of the unit is needed.

Use Password: 9109

#### Factory reset WARNING!

All files (TP, AS, APT) will be deleted and also pilots will be set to UNKNOWN – all pilot settings will go back to factory settings (save current settings before doing factory reset to USB stick at Setup>Pilot>Save user.)

#### Note

If LX Joy is not working after an update, use password 569 to force update.

### 2.3.6.2 Crash report

Saving a Zeus system crash report to a USB stick can be done by using admin password "27274".

If a system crash occurs, please send LX Navigation the file.

Once safely on the ground, put a USB stick into the Zeus and use the password in Settings->Service->Admin password to save crash report to USB key. This will help us to solve the problem and unwanted restarts.

### 2.3.6.3 Compass calibration

The compass module has to be connected to the main unit via the 485 bus (in the case of a double seater, connect to first seat). The module has to be installed horizontally without any pitch and, once done, enter the compass calibration menu. Position the glider to north and press SET, after that the glider will need to be positioned in all main magnetic directions as seen on the screen. When the glider is aligned correctly press SET. When a window with the sentence 'Calibration completed' is displayed, press 'SAVE' using the screen button and the system will exit back to the setup menu.

### 2.3.6.4 AHRS Level adjust (Pitch and Roll)

If the AHRS is not correctly aligned with the glider, then it has to be adjusted.

Changes in pitch in flight are influenced by changes of aircraft mass and changes of airspeed. This reference pitch corresponds to a single airspeed (indicated airspeed actually) and one aircraft mass. When the glider flies faster or slower, or if the glider is heavier or lighter, then the pitch angle deviates from the reference.

#### Adjustment procedure is:

- The internal reference level of LX Zeus instrument is most likely not to be ideal; therefore, adjustment will be needed. On the ground, put the glider fuselage in the position which best matches the angle of incidence for the reference airspeed. (Do not worry, if this is slightly wrong.) Adjust the Zeus to this level.
- Make a test flight with the glider. The aircraft mass should be as close to the reference mass as possible. Fly at the reference airspeed and observe the pitch indicated by Zeus. Record this pitch on paper. This observed pitch is the error, which needs to be corrected.

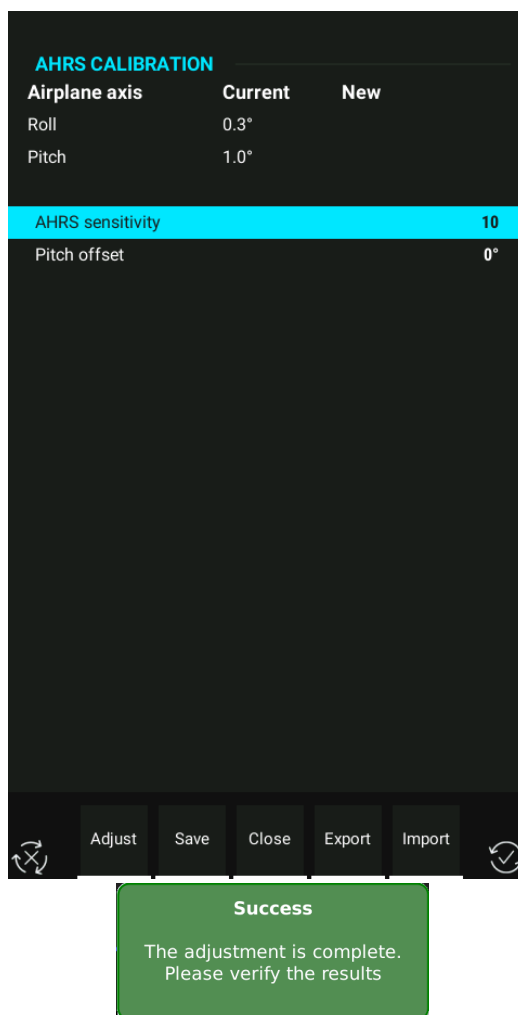

- Repeat the LX Zeus level adjustment, but now put the glider in such a position (lift or lower nose or tail wheel) that the pitch on the LX Zeus indicates the same angle as observed during the previous flight. Be careful to keep the wings level. This is now the reference position.
- Do not move the aircraft and adjust the Zeus to be perfectly levelled, as follows, under Instrument Procedure

Instrument procedure:

Go to SETUP / SERVICE / Level adjust

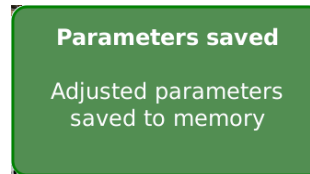

- When the glider is ready to have its AHRS calibrated press the on-screen button **adjust** (VARIO/FLARM)
- Wait until status bar reaches 100 %
- A message stating SUCCESS will appear
- If satisfied with the new settings press the **save** (TSK/MOVE) screen button
- A message stating Parameters Saved will appear

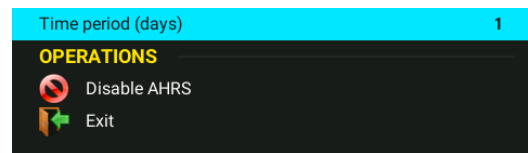

### Disable AHRS

To disable AHRS simply do as follows:

- Push on zoom rotary switch
- Go to setup
- Go to Admin password
- Enter password 2478 and confirm with a push on the Zoom rotary knob
- A disable AIRU window will open, there can be set:
  - Choose a **time period** (in days) for how long you wish to disable AHRS
  - **Disable AIRU** (AHRS) until next activation

### 2.3.6.5 Detected hardware

In this section is shown what hardware is connected (recognized) by the LX Zeus system.

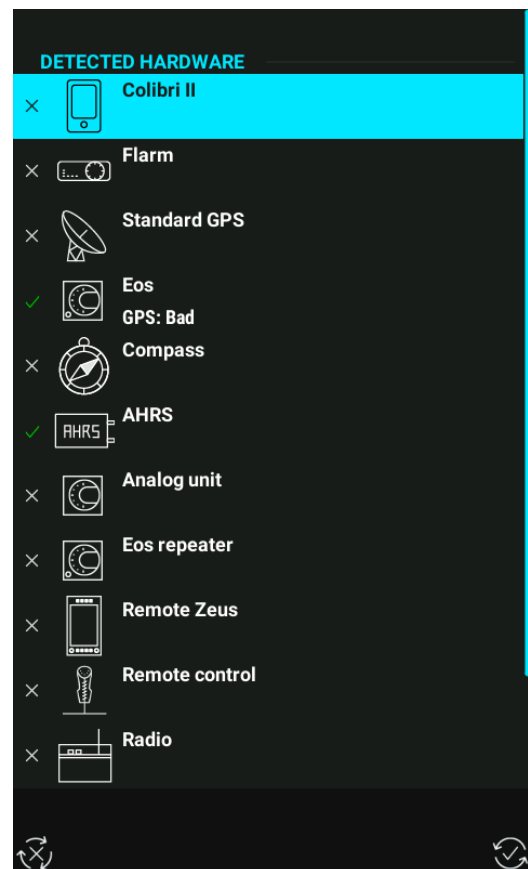

### 2.3.6.6 Radio (KRT2, ATR833)

KRT2 or ATR833 radios can be controlled from LX Zeus. It is possible to adjust some functions (this is the dialog available from the shortcuts menu):

- Volume
- Squelch
- Dual: If it is ON the radio listens to 2 frequencies at once. The Active one has the priority. This means that the radio will receive and transmit from the active frequency and only receive from the passive frequency (active one is priority receiver)
- Switch between Active and Passive frequency
- Set Active or Passive frequency values
- Set Active or Passive frequency name (only available when KRT2 is connected)

#### Radio wiring diagram:

Please check LX Eos manual for wiring diagram. For easy installation, it is possible to get a special LX Eos-Radio cable from LX Navigation.

**(Note: other radio types will be added in due course)**

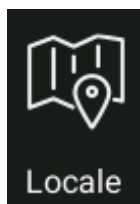
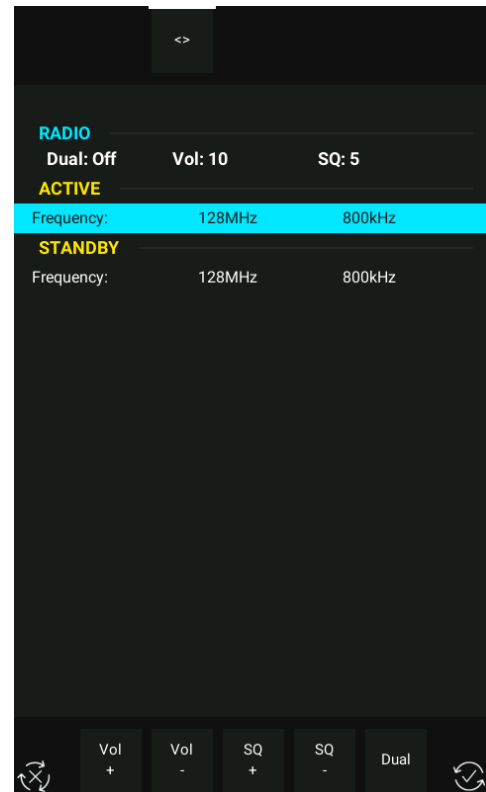

### 2.3.7 Localisation Settings

The following settings can be adjusted:

- UTC offset to get local time
- Date format
- Time format
- Position format
- Language

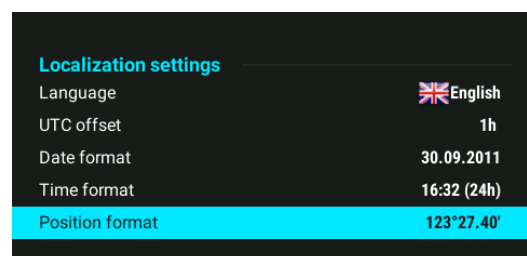

A restart is needed once any changes have been made.

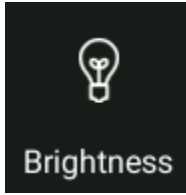

### 2.3.8 Brightness

The display used in LX Zeus is a high-quality sunshine readable display and its backlight will satisfy the pilot's requirements in all flying conditions. In the special case of increased backlight being needed, the pilot is able to increase the intensity for a limited time (30 minutes). After 30 minutes the backlight will go back to the default brightness. Brightness can be set by pressing the brightness icon in System settings.

**Note!**

Not valid for LX Zeus 4.3 and LX Zeus 2.8. They do not have the brightness adjustment option.

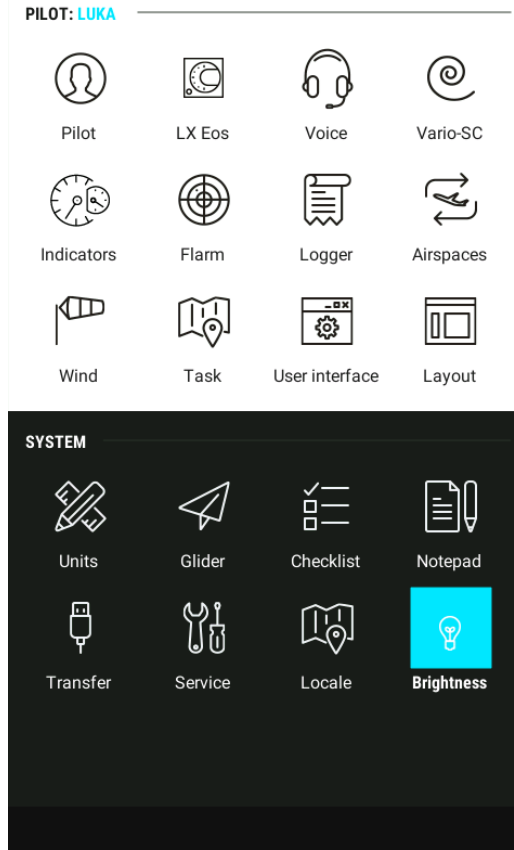



### 3 Navigation modes

LX Zeus offers three modes for navigation. These modes are:

- **APT:** navigation to airports stored in APT memory
- **TP:** navigation to turnpoints (TP)
- **TSK:** task navigation after task has been entered.

Switch between modes by pressing the **A-P-T** push button.

#### 3.1 Navigation in APT / TP or TSK mode

There are three navigation pages possible (APT, TP or TASK) and also 2 subpages are possible and all are selectable using the **SUBP** button.

##### 3.1.1 Sort by filter

In every selection, the following filters can be used to find the desired airport or turn-point:

- Name (alphabetical sorted from number-A-Z)
- Distance (closest TP will be shown as the first)
- Track (TPs -30 to +30 degrees from current track will be shown sorted by distance)
- Arrival Altitude

##### 3.1.2 Main graphic navigation page

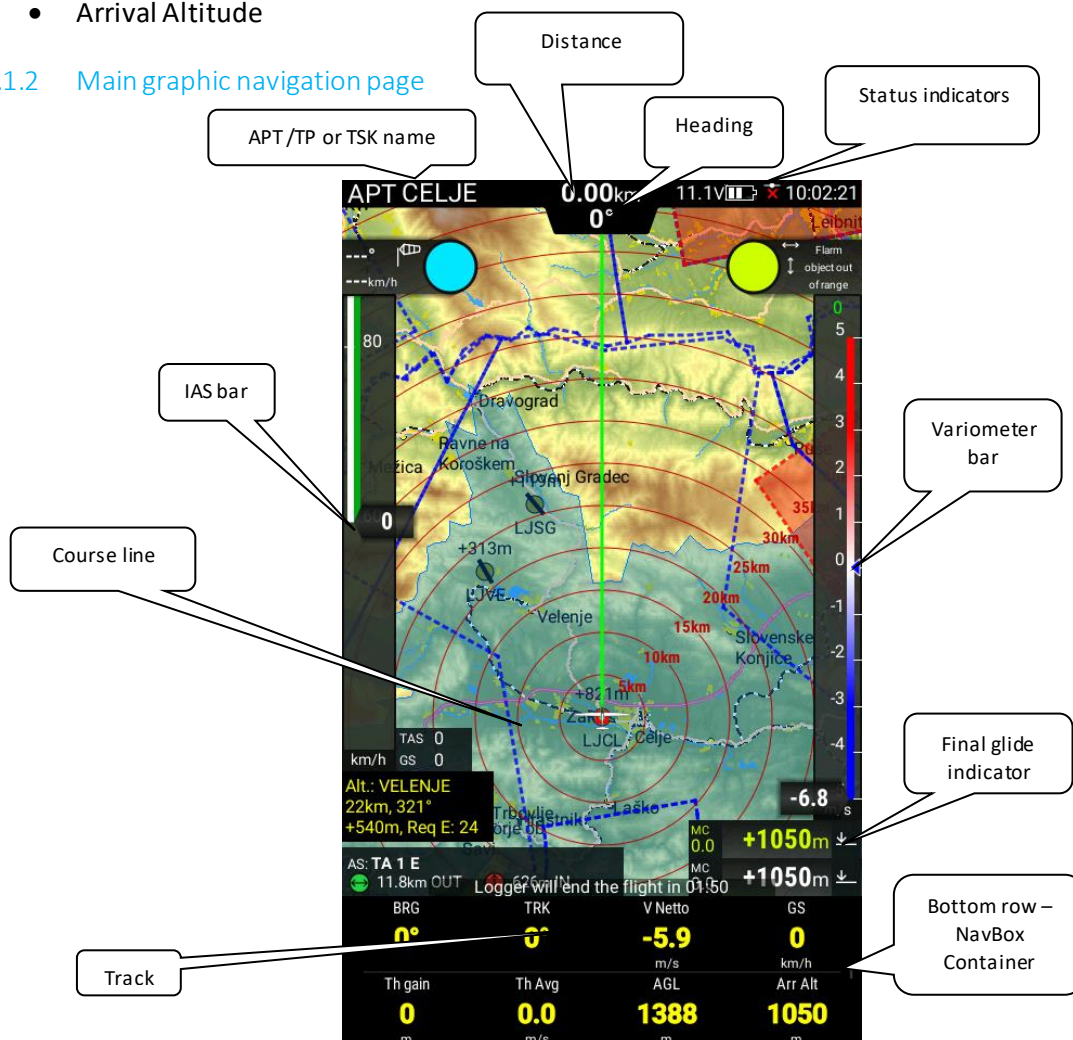

The bottom row consists of **NavBoxes**. Bottom rows are selectable by pushing button **1-4**. All NavBox positions are customisable by following the simple procedure set out below.

**Editing NavBox:**

- Give a long press on the Zoom rotary knob (**blue frame will appear**)
- Select the desired NavBox position by moving the blue frame using the Zoom rotary Select position to be edited followed by a short press of the Zoom rotary knob
- Select the desired NavBox from the list. Confirm selection by pressing the Zoom rotary knob or cancel the procedure by pressing the Volume rotary knob
- If the row is full, press the 1-4 push button and add to a new empty NavBox container that will appear. Use the same procedure for adding/editing described above
- To finish the editing process, press Volume rotary knob

3.1.3 Second navigation page (1<sup>st</sup> subpage)

The second navigation page is divided into two sections. The upper section consists of a vertical profile showing the terrain, glide path distance, airspace, selected TP/APT and cone.

The cone depends on the MacCready (MC) settings. The lower line is a MC setting of 0.0 and upper the line represents the selected MC value. If the glider icon is between the upper and lower lines it means that it is still below glide path for the selected MC, but that it could still reach its destination if a lower MC setting was set. If the glider is below the lower line it is too low and it will not reach the intended destination.

The lower section shows additional APT / TP data such as:

- Grass or asphalt runway with directions
- Elevation
- QNH alt
- Flight level
- QFE alt
- Frequency of the APT
- Your current radial
- Your current distance from selected APT / TP

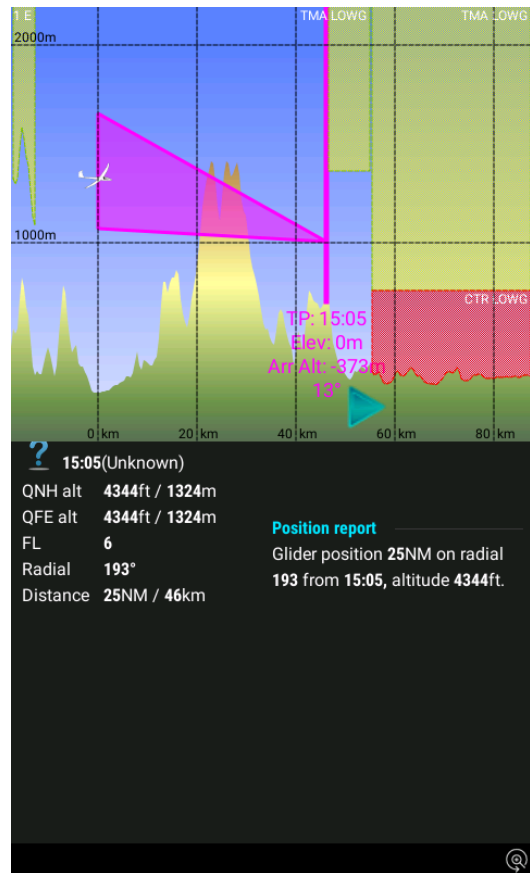

The lower section in TSK mode shows a circling log page, wind profile page and a statistics page. Use the **1-4** button to switch between information pages on this subpage.

Statistics contain:

- Legs
- Speed
- Distance flown
- Duration
- Vario average
- Circling on task in percentage

### 3.1.4 Third navigation page (2<sup>nd</sup> subpage)

The third navigation page shows terrain data that is split between a map and an AHRS (artificial horizon and reference system). If the LX AHRS is not connected to the LX Zeus system, only the terrain profile is shown.

The pilot can select full or half screen for 3D view with AHRS.

**Note!**

This 2<sup>nd</sup> subpage can be disabled under Setup>User Interface.

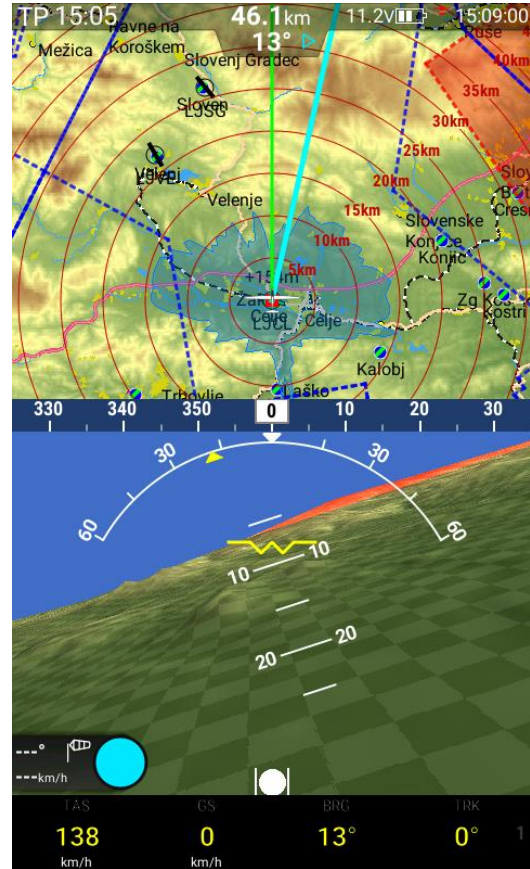

### 3.2 APT mode (navigation to airports)

LX Zeus' airport database is stored in a special **.af file** format (LX Navigation airport format). Only one **.af** can be active at the same time. To transfer and/or select new **.af** file go to Setup>Transfer>Airports.

APT mode consists of three navigation pages:

- main page is map navigation page,
- 1<sup>st</sup> page is a subpage with information about selected airport and glide path,
- 2<sup>nd</sup> page is a subpage with a map and a 3D view (with AHRS) or vertical profile.

Switch between pages by pressing the **SUBP** button.

**Note:** The second subpage (3D terrain) can be disabled (see Setup>User interface).

Airports are marked with a symbol (filled black line means airport with asphalt, a line without fill is a grass runway):



The RWY orientation shown matches the real situation. Extended Airport data is available in the lower section of the second subpage. Pressing the **1-4** button on the second subpage will bring up some additional screens (wind profile, thermal history, etc.).

### 3.3 How to select an airport?

Airport selection is available from any mode of operation and also from any subpage. Press the **SELECT** button (short press) and the selected menu will open. Use screen button **APT** with a short press of **TSK/MOVE** to start the selection dialogue. If already on the TSK navigation page, give a short press on the Volume rotary knob which is a shortcut to the APT selection menu.

Reachable APTs from the current position are shown in green, non-reachable are labelled red.

Scroll with the **Zoom** rotary knob to select a filter such as: **Country, Name, Distance, and Track or Arrival altitude** to reduce the number of offered Airports. If using a **sort by distance** filter, then it is not possible to use a named filter. Using a country filter will show airports only from the selected country. After the airport of interest is found confirm the choice with a short press on the Zoom rotary knob. The APT screen will open giving navigation to the chosen destination.

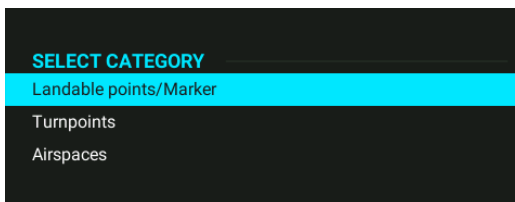

**Note!**

When using the **Name** filter, input first letters of the airport name. Use the Zoom rotary knob to scroll and press it for confirmation. You don't need to input all characters, just first two or three and after that you can go on by pressing the Zoom rotary knob. Input of more characters reduces the number of possible airports.

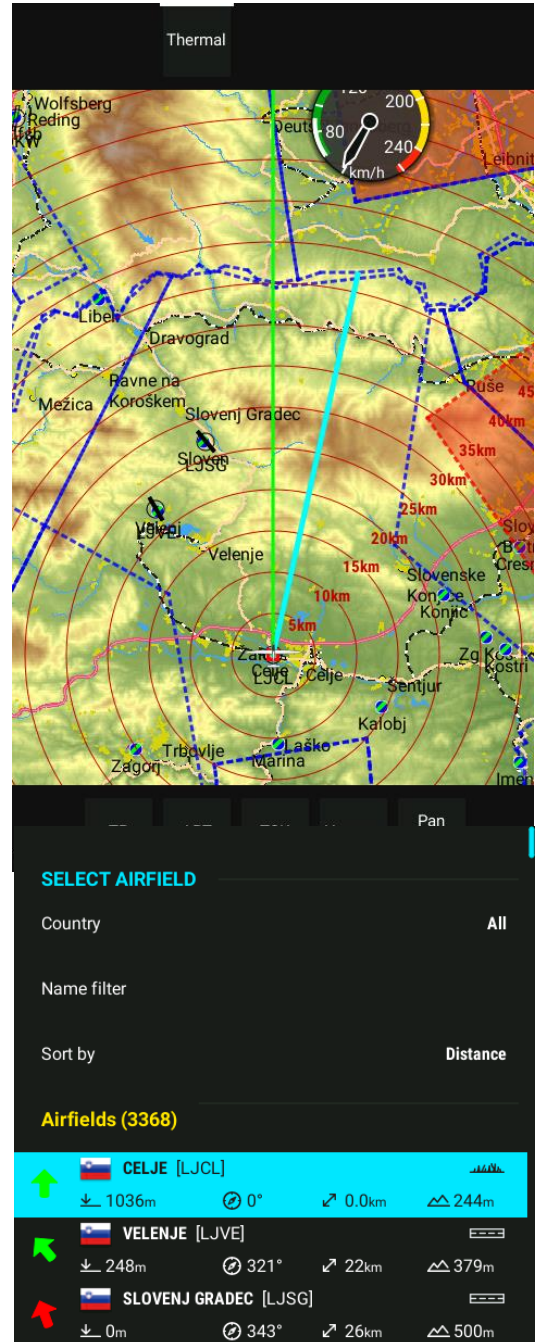

### 3.3.1 APT selection from NEAR function

LX Zeus also offers **NEAR** function. After a long press on the **SELECT/NEAR** button, the nearest **Landable points** and **User markers** will be offered. The list includes airports from the airport database, turn-points that are declared as landable and Markers.

**Note!**  
Selection is limited to 200 nearest points

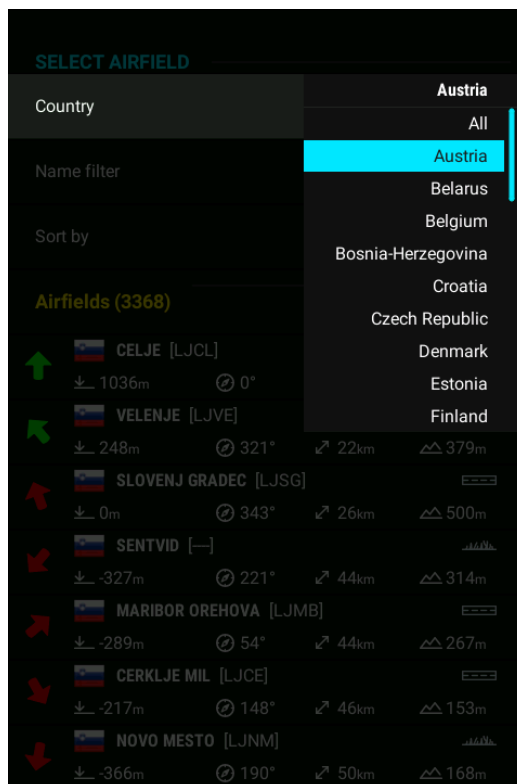

### 3.4 TP mode (navigation to turnpoints)

TP and APT modes are similar in structure. The only important difference is that the navigation is towards turn-points that are stored in the turn-point files. Turn-point files (.cup or .cupx) should be uploaded via a USB stick. (See **Setup>Transfer** for details.) An almost unlimited number of .cup/.cupx files can be uploaded. Because turn-points can have different **attributes** the symbols that represent the various types are different.

TP mode consists of three navigation pages (main page is map navigation page, 1<sup>st</sup> subpage with information about selected airport and glide path, 2<sup>nd</sup> subpage with a map and a 3D view (with AHRS) or vertical profile. Switch between pages by pressing the **SUBP** button.

If using **.cupx** files turn-point images are shown on 1<sup>st</sup> subpage. A .cupx file can be prepared on a PC or on LX Zeus. To add pictures to turn-points use Select TP menu. On the bottom of the menu is shown the **Upload photo** screen button. Use it to transfer pictures from an USB stick to the selected turn-point.

**Note:** The second subpage (3D terrain) can be disabled (see Setup>User interface).

Extended TP data is available in the lower section of the first subpage. The upper part of the display (1<sup>st</sup> subpage) is vertical terrain profile.

To activate the screen buttons for the TP options the Zoom rotary knob should be pressed when on TP screen (not at APT or TSK).

**Note!**

Up to **three** turn-point files can be active at the same time. The activation should be performed under Setup>Transfer. Turn-points included in all three files will be available for navigation. The first file (TP/TSK/Eos) will import tasks. Imported tasks are available in TSK navigation mode.

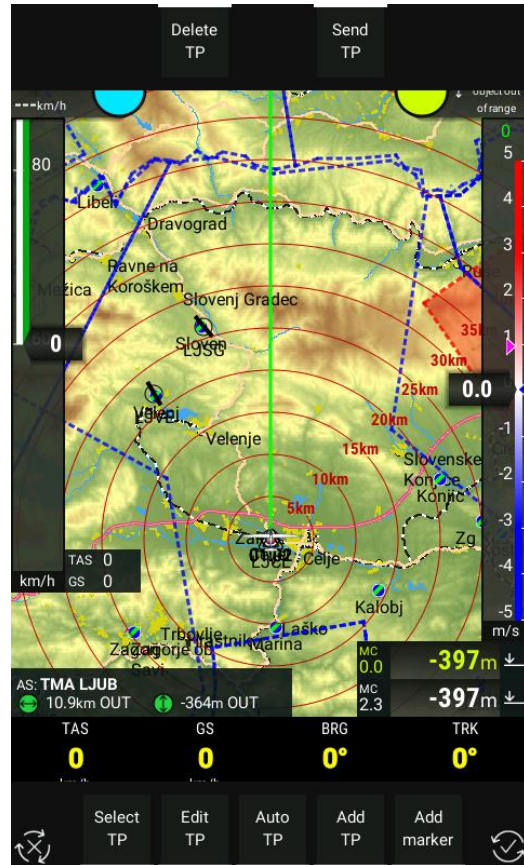

### 3.4.1.1 Edit TP

Press Zoom rotary knob on main TP navigation screen, select screen button **Edit TP** and a new window called Edit turn point will open.

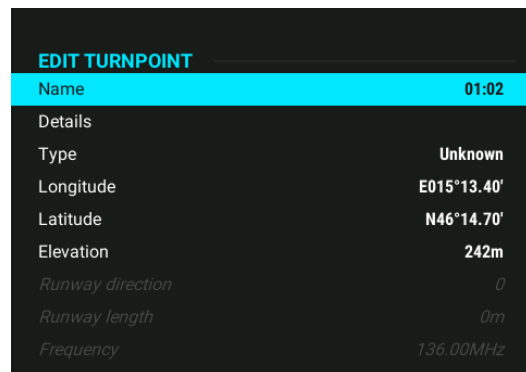

### 3.4.1.2 Create User turnpoints

User turn-points are turn-points that are created by the pilot on LX Zeus

#### Auto TP

If Auto TP is selected, a user TP will be created, with the current position and the current time as its name. To edit an Auto created TP use the Edit TP function.

#### By hand

Press the **Zoom** rotary knob on the main TP navigation page and a menu with screen buttons will open. Press **Add TP**.

The following information can be entered:

- Name.
- Details (not obligatory).
- Type (grass, field, tower...).
- Longitude, Latitude.
- Elevation.

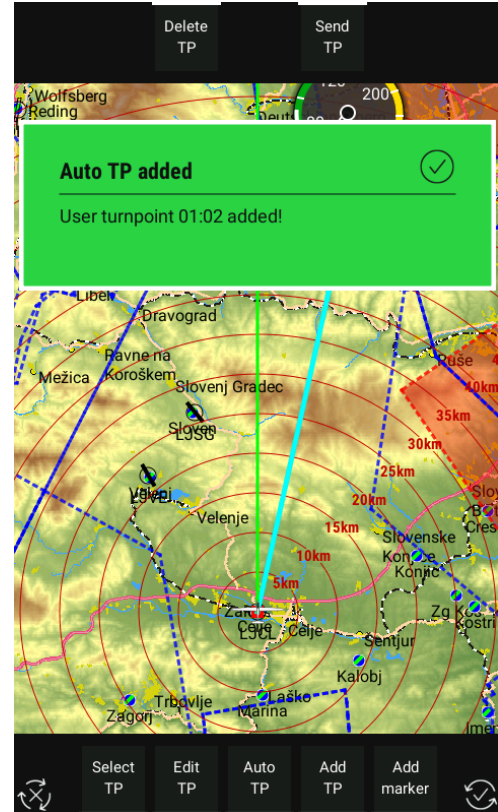

Other input fields may not be highlighted due to the turn-point type being added. **Finish** the process with **Add** turn-point.

#### Note!

**Type** option offers plenty of turn-point designators. The designator defines the symbol that will appear on the display. A landable point will be shown on the list in NEAR function.

### 3.4.1.3 Add Marker

The philosophy of having a marker is to mark a position, to which the pilot might need navigation assistance (landable field, etc.).

For example, if flying towards a non-landable area, and the last landable field is seen below, then, over this landable field, a marker can be created. It would then be easy to navigate back to that marker, which can be selected at NEAR/TP, or at select TP.

There can only be one marker at a time. If another marker is created, the first one will be replaced by it. The marker can be changed to a regular more permanent TP via EDIT TP. Such a turn-point can be deleted via DELETE TP.

### 3.4.1.4 Delete TP

Only user created turn-points and markers can be deleted. To delete a TP the Zoom rotary knob should be pressed, then select screen button DELETE TP and a new window will open. Select the TP by rotating the Zoom rotary knob and confirm it with a short press.

### 3.4.1.5 Send TP

If Send TP is selected, then the current selected TP will be sent to the second seat (all info about the TP will be sent).

## 3.4.2 Selecting Turn-points

The selection process is similar to APT. Use **SELECT** button to start the process and press on-screen button **TP**. Country, Name and sort by distance, track, arrival altitude filters will expedite selection. Turn-points are displayed by symbols. If on a TP navigation main page the shortcut (press Volume rotary knob) can be used.

### Important!

Turn-points without **country designators** are selectable only when using **Country "All"** option. This is also valid for user turn-points. Check and correct all files manually before uploading them to LX Zeus.

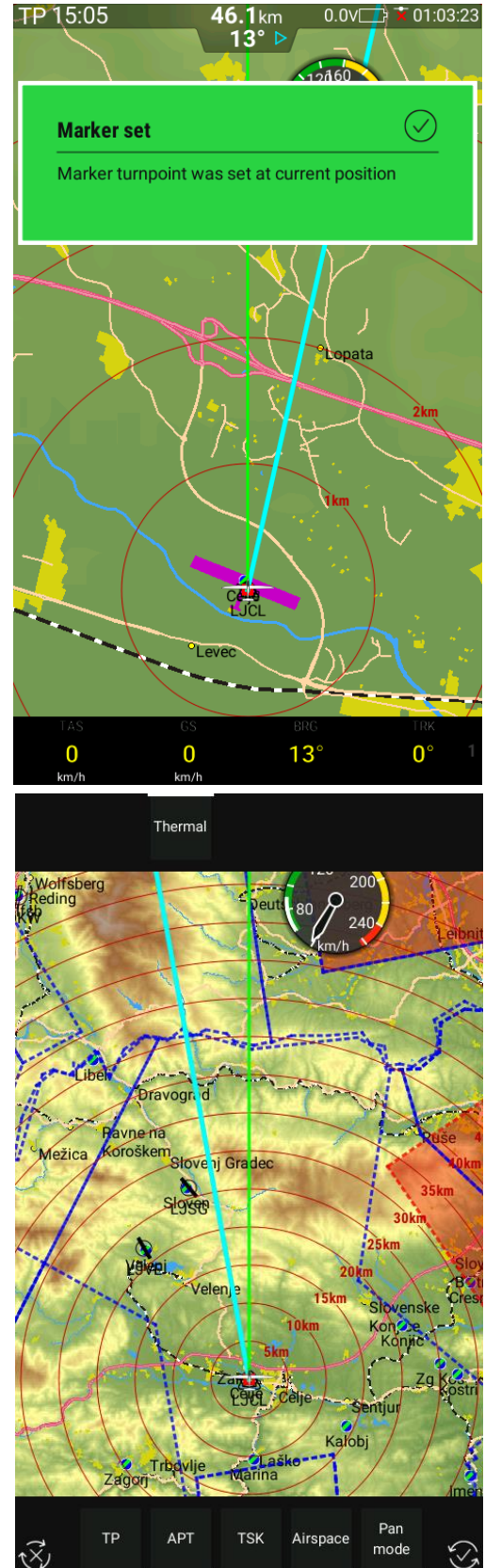



### 3.4.2.1 Selection from Near

LX Zeus Near function offers Turn-point selection based on distance. It is also uses a Country filter, use **All** if you want to select from all turn-points.

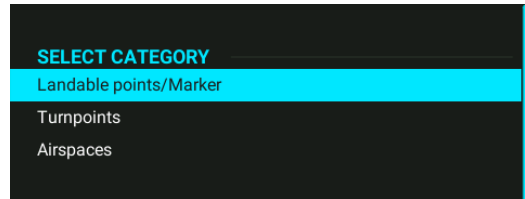

### 3.4.3 Uploading TP photo

It is possible to upload a photo and assign it to a TP.

The procedure to upload a photo:

- Insert USB stick
- Press SELECT button
- Select TP
- Choose with the Zoom rotary knob to display the TP you wish to assign new photo to
- Select - Upload photo
- Choose the photo on USB stick
- Confirm with a push on the Zoom rotary knob

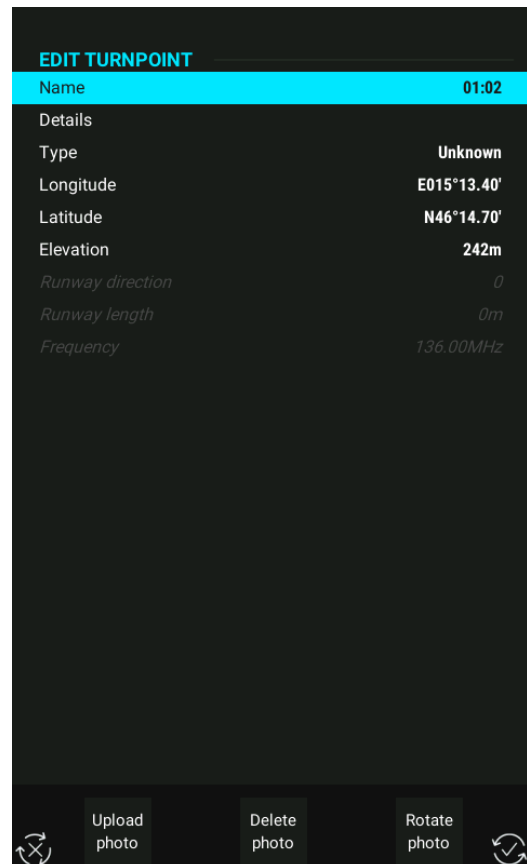
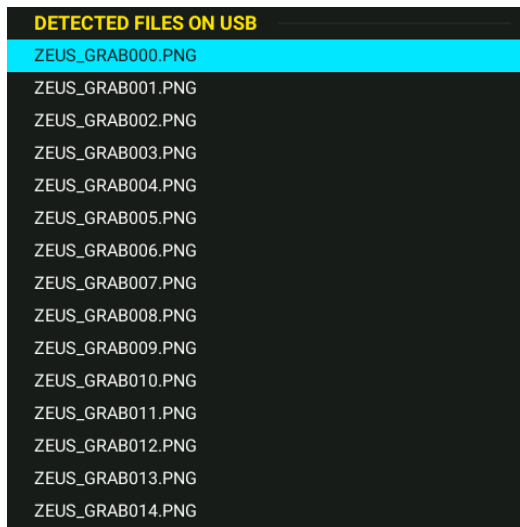

### 3.5 TSK mode (navigation on task)

Every task consists of at least a start point and the finish point. There may be multiple turn-points between the start and finish point. Take-off and landing points can be added (this doesn't have any influence on task statistics).

#### 3.5.1 Task organization

Zeus has a storing capacity for 100 tasks. 51 tasks can be imported from one **.cup** file and such tasks are called **imported (IMP)**, the user of LX Zeus can create another 49 tasks. They are called User (USR) tasks. After creating or selecting TSK, the TSK will be automatically declared (and sent to all connected flight recorders).

To delete all existing USR tasks go to Select TSK dialog and then select Clear all. Zeus then asks confirmation and deletes all USR tasks.

##### 3.5.1.1 Task declaration

Declaring the task is an automatic process. After a task is constructed, and exit is pressed (Volume rotary knob), a message on the LX Zeus screen appears: TASK DECLARED! This means that LX ZEUS will start sending the declaration data to connected flight recorders. The declaration is sent to Eos, Colibri II, Colibri X, Era etc. automatically – with all TPs, edited zones, limitations etc...

Eos and Colibri II have the priority and will receive the data first. After this, the declaration data will be sent to FLARM. This process will take about 30 seconds. After the process is finished all LED lights will switch off on the FLARM display and the red POWER light will start blinking. This means that the process of sending task declaration to FLARM is finished.

#### 3.5.2 Task selection

To select a task from the LX Zeus internal task database, the pilot should use the **SELECT** button and then select the screen button **TSK**. Use the Zoom rotary knob to select the task of interest. Confirm selected task by pressing the Zoom rotary knob and another window with task details will be shown. Choose the option for the Finish altitude of the task to be less than 1000m below the altitude at which start line was crossed. (as appropriate). The Final Glide will be calculated in correspondence with this altitude, but only if the option is selected.

Exit by pressing the Volume rotary knob twice, or wait until the window closes automatically (if auto close inactivity timeout is enabled).

**Note!**

Tasks that you want to upload to LX Zeus should be a part of a **.cup** file and should be selected under SETUP>TRANSFER as **TP/TSK/Eos file**. **It is very important that you name tasks, otherwise the Zeus won't recognize them.**

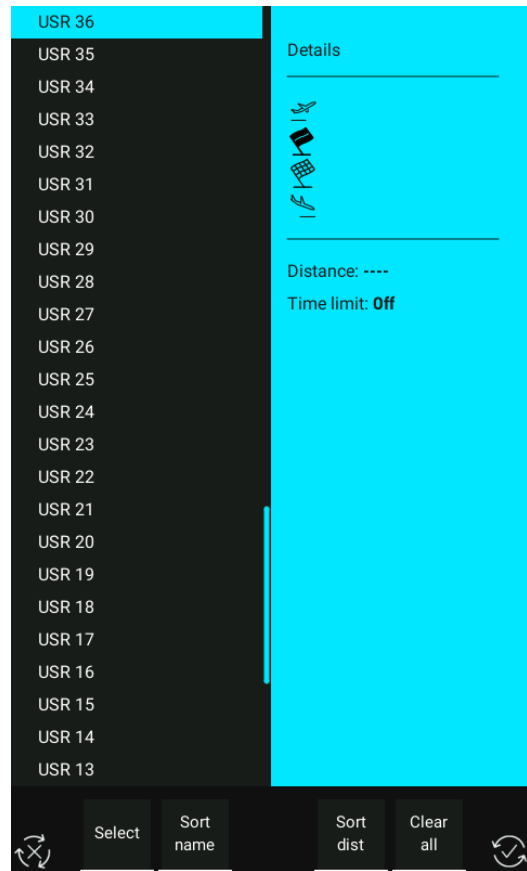

### 3.5.3 Task creation by hand

To create a new task press **TSK/MOVE (short press)** or give a short press on the **Zoom** rotary knob if you are on TSK main navigation page. The task can be created by hand by using **NEW** or **EDIT** screen buttons. Edit will make it possible to edit an existing task and New will offer the creation of a new task. Both tasks will be saved under the USER part of the task internal database (if editing an IMP task, it will automatically change from IMP to USR).

#### The procedure:

- Press TSK/MOVE button
- Select screen button NEW (TSK/MOVE) or EDIT Task (VARIO/FLARM)
- If an AAT task, then add time by pressing the Zoom rotary knob and rotate Zoom/Volume rotary knob, terminate by pressing Zoom rotary knob
- Rotate Zoom rotary knob to add Task name – press Zoom rotary knob and add name
- Rotate Zoom rotary knob to TPs – press Zoom rotary knob and Select/Insert TP or APT
- To finish the task creation procedure, press the Volume rotary knob – a message informing that the task is declared will be shown

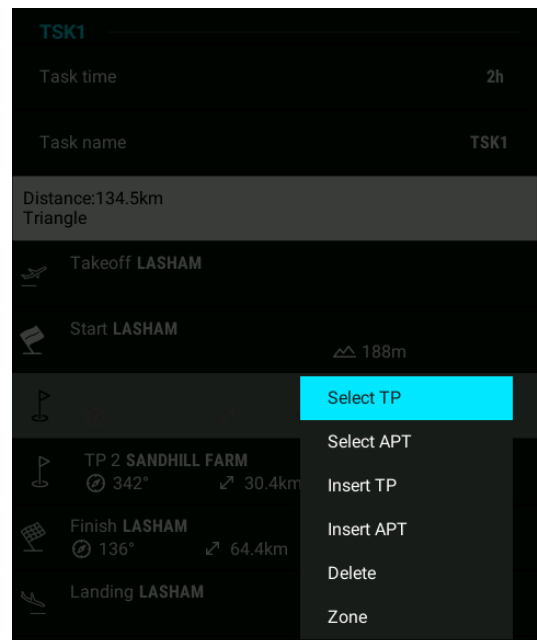
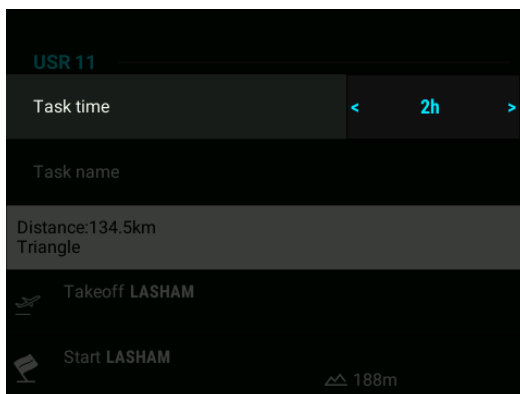
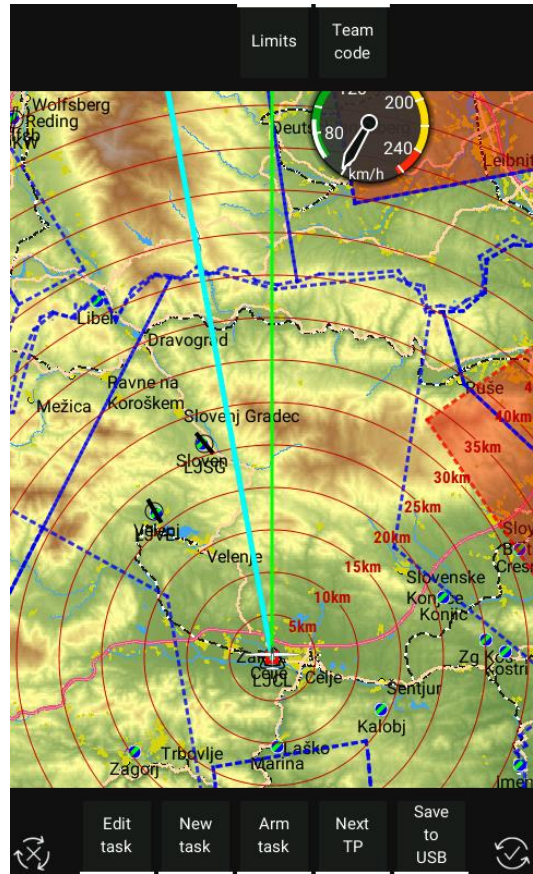

### 3.5.3.1 Creating a task in Pan mode

It is possible to create a task in Pan mode by following these steps:

- Press SELECT button on TSK screen
- Select Pan mode on screen button
- Navigate to the point on the map using the Zoom/Volume rotary knobs
- Select New task
- Select Add TP (the first TP you select will be your Start and Finish point)
- Add as many TP's as required
- When adding TP's has been completed select Finish task
- The task can be edited in edit mode - Start, finish, TP's, zones

When the task is created, it is declared and sent to Colibri II / Colibri X / Eos / Era / Flarm etc automatically.

#### Note!

An active zone has a different colour to an inactive zone (colours can be adjusted under Setup / User Interface / Task Colours.)

#### Note!

You can see the entire task on the map at once by using TASK ZOOM. Access TASK ZOOM by rotating Zoom rotary knob. The task zoom is active only on the ground!



### 3.5.3.2 Create and Edit Zones

The **ZONE** function makes it possible to create any known geometry for turnpoints, start and finish point. The zone can be edited by selecting **TSK EDIT/ select TP / ZONE**.

After a press on the Next zone or Previous zone buttons, the pilot can change zone settings quickly without any additional actions.

For START and FINISH zones the pilot can select if this zone is a straight line or not.

**Auto next** option enables the Zeus automatically to switch to the next turnpoint once the sector has been reached. This function is active by default if the **sector's radius is below 10 km (racing task)**. Larger sectors do not have this option as a default. If **Auto next NO** is active, **MOVE** function (for AAT) will become active and that makes it possible to modify the task distance even before flight.

MOVE during an active TSK is also possible. A long press on the push button **TSK/MOVE** will open a Move window. The 'custom turnpoint' can then be moved by rotating the Zoom and Volume rotary knobs. The important information is displayed next to the moved turnpoint (Total distance, Required speed, final glide at MC 0.0 and selected MC).

**Note!**

Default task zones can be adjusted under Setup / User Interface. You are able to adjust default start, waypoint and finish zone to make task creation easier.

**Note!**

AAT task – if the sector is bigger than 10km, then AUTO next won't be active. If the sector is smaller than 10 km, then you have to uncheck MOVE in the ZONE menu

### 3.5.4 Task Functions

Automatic and manual starts are possible by using functions ARM and NEXT TP. All functions are available by pressing the Zoom rotary knob when on the TSK navigation page or by pressing the **TSK/MOVE** button on other pages.

#### 3.5.4.1 Task Start

To start a task automatically use the ARM command which is displayed after a press of the TSK button. Arm means that the task will be started automatically after crossing the start line.

The start line can be crossed multiple times, the time of the last valid start will be used for calculation of statistics. Every valid start is indicated by a green message on the screen.

Under Settings>User Interface>Track/destination settings can be selected whether navigation is aimed at the zone's center or the zone's closest point.

During flight the task can be disarmed. Activation of ARM and DISARM are clearly shown on the display in a message and by an ARMED icon.

If pressing ARM before crossing the start line is forgotten, and the glider is already on the task, then the second option is to press Next TP. Next TP command will change over to next TP every time when activated, regardless of whether the glider is in the sector or not. It will also take the latest start line crossing time, to ensure that task statistics will be correct.

#### 3.5.4.2 Task Restart

After a task has been started a restart can be done at any time. Use the **Restart** button in the TSK menu. The **Restart button** will become active once the task has started. After restarting all task statistics data will be deleted and ARM status will become active again making it possible to do another automatic start.

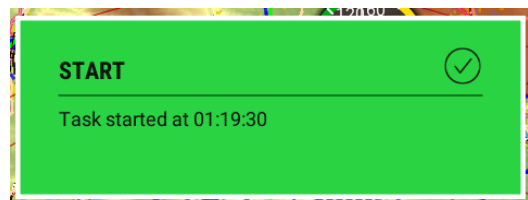
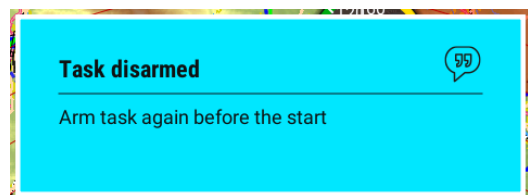
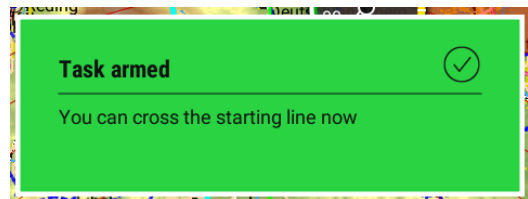
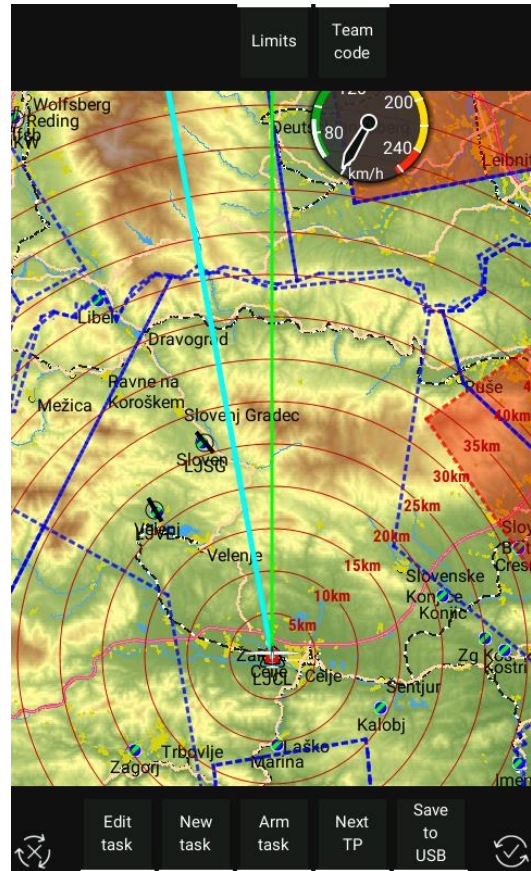

### 3.5.4.3 Next Turnpoint

Changeover to next turnpoint can be done automatically or manually. Automatic changeover will occur when **Auto next** of the individual zone is enabled. If the zone is not Auto next, then the message INSIDE zone will appear. If going to the next turn-point, press TSK button and then press NEXT TP screen button.

Observation zone (TP 1) 01:02	
Type:	Symmetrical
A21:	0°
R1:	3.0km
A1:	45°
R2:	0.0km
A2:	0°
Auto next	✓

#### Default setting for Auto next:

- If R1 is set below 10 km then Auto next is activated (automatic changeover is enabled).
- If R1 is set above 10 km then manual changeover is necessary.

When flying a task, and when a new TP becomes active, the same TP is set as the navigating turn-point on the TP page.

**Note!**

Manual changeover is only possible by using the **Next TP** command. **Next TP** is always active and it will execute changeover to next TP at any time. Activating this command, when still out of the sector, will degrade statistics data. Solutions: delete TPs that are not required, or extend the zone/sector of TPs.

### 3.5.4.4 Saving TSK to USB

LX Zeus offers the option to save created or edited tasks to a USB. A USB stick has to be inserted into the USB port. After the creation of a Task, press the Volume rotary knob to get out of edit menu and declare the task. After that, press TSK button and press Save to USB using the screen button. The Task will be saved to the USB stick as a .cup file with current task and all TPs and zones on this task.

### 3.5.4.5 Clear TSK

When in task editing menu, the whole task can be erased. First press Clear task screen button, then press YES to confirm the choice or NO to terminate the process without erasing the task.

### 3.5.4.6 Team Code

Team code is a feature that gives the capability of visualizing the position of a wingman and yet keep it secure. A short press on the TSK button will bring up the Team code screen and a menu requiring the team code and reference point will appear.

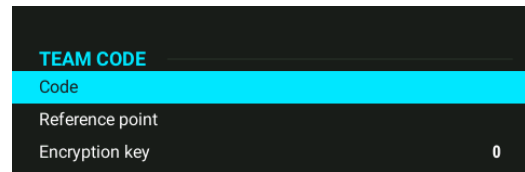

To use this feature there are three NavBoxes available on LX Zeus (TEAMCODE, TEAM BEARING and TEAM DISTANCE).

Before sending a position with the team code all partners should use same reference turn-point. For better indication (more accurate) a reference point which is 50-150 km away from every position in the flight should be chosen (for example the task that is flown should be in the 50-150 km radius of the reference point; if the task is bigger a second reference point should be chosen and entered once an agreed distance has been flown). In flight, when partners are interested about their location, team codes should be exchanged via radio. The pilot's current code is visible in the Team code NavBox. Partners are able to see bearing and distance of each other in the TEAM BEARING and TEAM DISTANCE NavBoxes.

The feature works on the principal of the polar coordinate system. The baseline condition is having the same reference point. When this is chosen, LX Zeus calculates distance and bearing from this reference point to the pilot's location and codes it into Team code. The first two characters mean the angle and the last two the radius from the reference point. When this information is given to a partner with the same reference point chosen, LX Zeus can calculate direct bearing and distance to the other partner. The process works in both directions between partners.

### 3.5.4.7 Limits

Here are the task start conditions that can be selected. It is possible to:

- Define **gate time**
- Define **before start:**
  - Below altitude
  - Below time
- Define **start conditions:**
  - Start altitude
  - Start ground speed

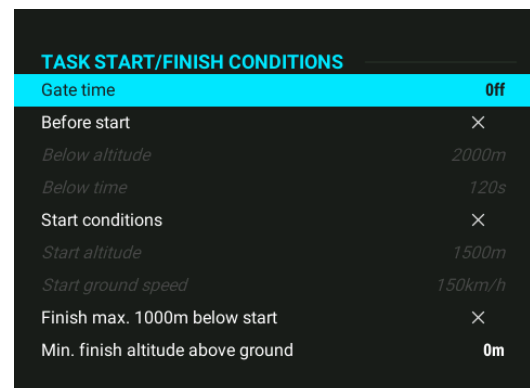

For the explanation of these terms read more under chapter Start Conditions/Limitations

### 3.5.5 MOVE Function (during flight)

When flying an AAT, big sectors are set and therefore the pilot has to decide where to turn to the next turn-point. The MOVE function helps the pilot to find an optimum solution. After a long press on the **TSK/MOVE** button the MOVE function will become active. Use Zoom and Volume rotary knobs to move the turn-point. All task relevant data that is affected by the move is displayed next to the zone.

During straight flight, when far from the zone, the track will appear in the zone in the MOVE function. When the glider is in the zone, the real-time picture (glider with its track), will also be shown on the MOVE dialog.



### 3.5.6 Task Zoom

By rotating the Zoom rotary knob to the left the Task zoom will be activated which will show the whole task on the screen. Task zoom will show all turn-points (moved and modified) with airspace. Task zoom is not visible while flying, only on the ground.

## 4 Airspace Management

Airspace on LX Zeus can be managed by the pilot to achieve the optimum relationship between loading the display and its readability. Too much information will reduce the readability of the display.

### 1.1 Basic airspace settings

Settings are available under **Setup > Airspaces**. The user can select warnings and appearances related to the zoom level.

#### 4.1.1 Hide airspace above

The airspace sections that are much higher than the altitude of the glider are not relevant. Disabling them will significantly reduce the density of information on the display. Use **Hide airspaces above airplane** to define the altitude margin that considered to be required for a safe flight.

#### 4.1.2 Other settings

**Hide above QNH altitude** allows a selection of the QNH altitude above which the airspace should be hidden.

**Horizontal** and **vertical distance** warnings can be set also in this section. LX Zeus will warn a user at a predefined warning distance. Default settings are 100m vertically and 2 km horizontally.

**Warning timeout at takeoff** allows a choice as to how long after the take-off there won't be any airspace warnings.

#### 4.1.3 Define appearance of airspace related to zoom level

Zoom levels can be selected at which different airspace types will be visible. Use the **Show on zoom** function to define to which zoom level the airspace type is to be visible on the display. Two extreme situations are described with **always** and **never**. Factory default settings for all airspace types are **always**.

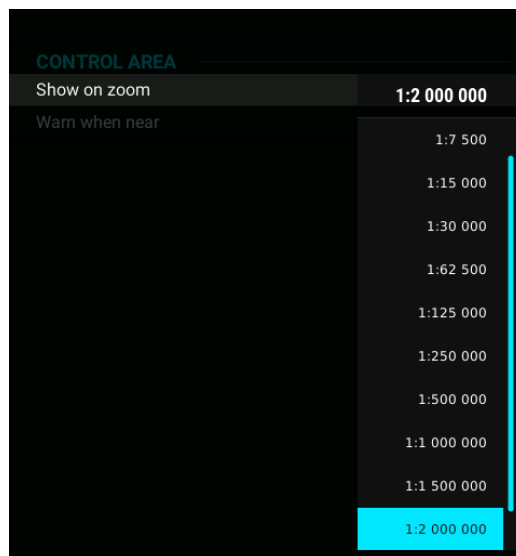
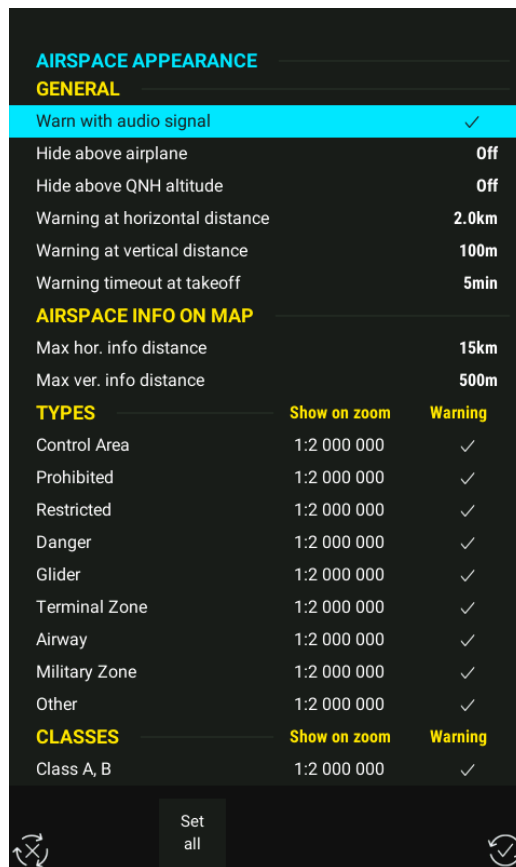

#### 4.1.3.1

If set to disabled (✘) the airspace info box for this airspace type will not appear on the screen. Setting checked (✔) will produce airspace info box information.

The airspace info box is an indicator on the main screen. The pilot is able to move/resize the box and also to customize colours. This can be done under **Setup > Layout**.

The airspace info box contains airspace name, horizontal and vertical distance and is by default positioned in the upper section of the display. The nearest point to entering the airspace becomes visible on the display. As long as the warning isn't critical the text colour is blue.

Airspace is displayed at 1<sup>st</sup> subpage in different colours (yellow and red). Airspace is also seen in a 2<sup>nd</sup> subpage, where the page is split between a map and a vertical profile (but only if AHRS is not connected to the system).

#### Explanation of airspace info box

The picture shows that the glider is in the CTR MARI airspace. It shows that the glider is horizontally 11.2 km inside and vertically 82 m outside. The red warning confirms that the glider is inside, the yellow that it is close and the green warning means it is outside.

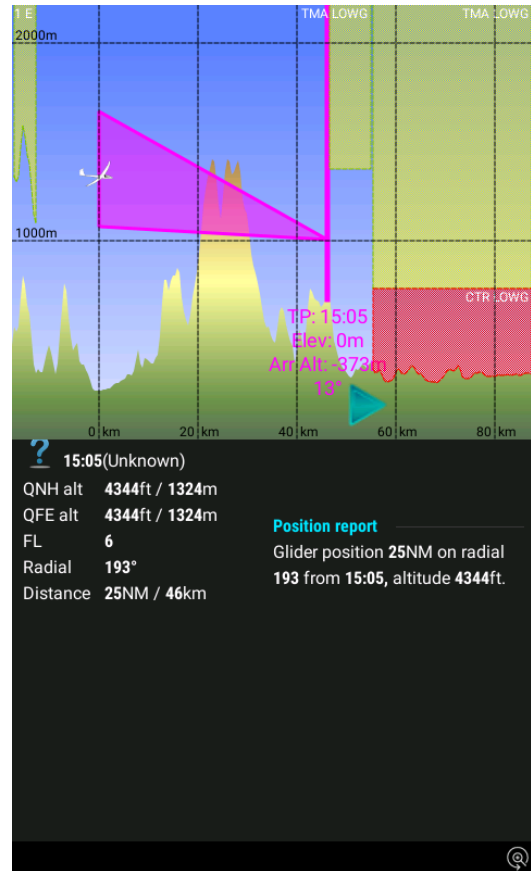

#### 4.1.4 Disabling airspace sections

During flight, airspace warnings may appear on the screen (picture on the right). Pressing on one of the screen buttons can easily disable the warning. Airspace warnings can be disabled for specific amounts of time (5 minutes, 10 minutes, 30 minutes, 1 hour, 3 hours or for whole day).

Airspace can also be disabled whilst on the ground. Press SELECT button to open airspace dialog. Airspace is sorted by distance. In the upper part of dialog there is a list of airspace with name of the airspace, horizontal distance and operating altitude from and to in meters/feet and also as a Flight level. The bottom part of dialog shows airspace around the glider. The colour of the currently selected airspace is blue.

Different airspace can be selected with the Zoom rotary knob. By rotating the Volume rotary knob the zoom level can be changed. After a press of the Zoom rotary knob or a press on the EDIT screen button, a dialog with additional options for selected airspace will appear, as follows:

- Airspace type
- Airspace class
- Disable airspace until specified date

A screen button DISABLED ONLY will show only disabled airspaces.



Edit airspace dialog after a press on EDIT button

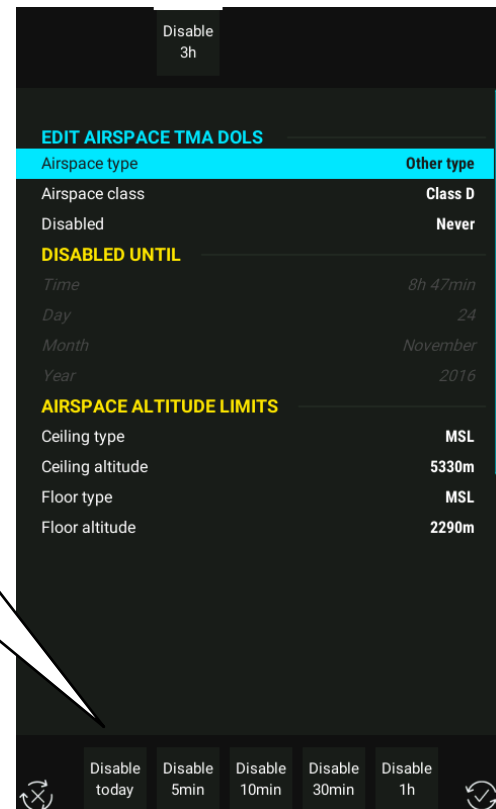

## 5 [GPS signal management](#)

LX Zeus has three GPS signal inputs, they are on the back of the unit. The following devices can be connected:

- **Colibri II**
- **Flarm or any device with NMEA output**
- **LX Eos/Era via CAN bus**



### 5.1 Colibri II socket

The **Colibri II** socket can be used only to connect a Colibri II unit. It delivers power (5V) for the Colibri II and sends/receives data directly without any data interface. The communication is bidirectional. Every unit equipped with Colibri II is supplied with a suitable connection cable (USB mini to 6-pin RJ11).

### 5.2 Flarm plug

A **Flarm** marked input is a plug and play solution for connecting any unit that has 6-pin RJ11 IGC compatible connector. **This port also delivers 12V.**

The following units can be connected without any additional adaptor:

- Colibri, LX 20 – 2000, VL, LX Flarm RB, LX Flarm MB, Flarm (Swiss)

### 5.3 LX Eos – CAN plug

LX Eos/Era connects to a CAN port, it doesn't matter which one is used. If an Eos is connected to the system, please check that there is no CAN terminator used on the CAN bus (CAN terminator is already built-in to the inside of a LX Eos/Era device).

### 5.4 GPS signal for navigation

All GPS inputs are used on LX Zeus. This means that LX Zeus is supplied with valid GPS signal as long as at least one connected GPS receiver delivers valid data. A symbol positioned in the right upper corner of the display shows GPS signal status:

- red GPS BAD
- green GPS OK
- white symbol with ☒ means no GPS data is present



#### Note!

Colibri II is powered from LX Zeus. All settings and declarations are sent from LX Zeus to Colibri II/Eos/Era/MOP/Flarm. There is no need for any additional setup on Colibri II/ Eos/Era/MOP/Flarm.

#### Note!

LX Zeus can adapt baud rate to any value between 4800 and 38400 automatically, so baud rate of GPS source connected to Flarm input does not matter as long as it is in the range (4800-38400).

## 6 [LX Zeus and LX Eos/Era](#)

LX Eos/Era and LX Zeus together create a very compact and robust system. They are connected with a single CAN cable (use CAN port on both devices).

All the data and power supply is transmitted through this cable. LX Zeus and LX Eos transfer all the necessary data from one to another. When LX Eos/Era is connected to LX Zeus all settings for LX Eos/Era are made on LX Zeus and transferred to LX Eos/Era.

When LX Eos/Era and LX Zeus are connected, the setup screen cannot be seen on LX Eos/Era, because the setup is done on LX Zeus. If the main power supply fails (ie.: Zeus does not work anymore), and it is still in flight mode, LX Eos/Era will keep working as it has an integrated battery with about a three hour duration. In such cases the Setup page will appear on LX Eos/Era and there is an option to set all important parameters on LX Eos/Era device. To see LX Eos/Era setup structure, please check LX Eos/Era manual.

LX Eos/Era has an integrated ENL sensor.

### 6.1 [LX Eos/Era power management](#)

Connect the main power cable with a switch to LX Eos/Era. Immediately after LX Eos receives power, the LX Zeus will automatically switch **ON**, without any pilot interaction. When the main power from LX Eos/Era is cut, LX Eos/Era will start a 3 second countdown before it turns OFF. LX Zeus and other CAN devices are turned off immediately. When for some reason the main power supply is lost during flight, LX Eos/Era will continue to record the flight for about 3 more hours.

The internal battery inside LX Eos/Era is automatically charged when there is a 12V power supply and this means that it is always available to provide internal backup power supply for LX Eos/Era. The charging process of an empty battery takes around 2 hours.

## 6.2 LX Eos/Era – Zeus interaction

After connection between LX Eos/Era and LX Zeus is established, both units will start to communicate over the CAN bus. The connection is established automatically without any pilot interaction.

### 6.2.1 Commands and declaration transfer to LX Eos/Era

Every time the system is turned on the following data is sent to LX Eos/Era:

- **Pilot data:** After initial setup on LX Zeus (also pilot 2<sup>nd</sup> name in the event of a double seater configuration)
- **Recording interval**
- **Other data** related to flight recording with recording (Event repetition...)
- **Selected task:** the task will become declared
- Active turn-point file (.cup in TP/TSK/Eos slot)
- Active turn-point navigation
- Other vario settings

A long press on **the EVENT** button, will send the event command to LX Eos/Era. The event command can be sent also from a second seat.

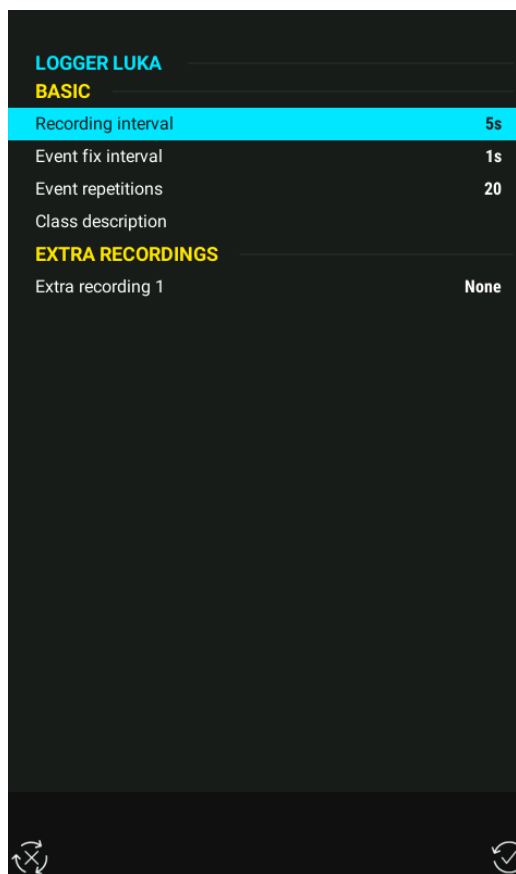

**For more information about LX Eos/Era system, refer to LX Eos/Era manual.**

#### Important!

**Any change** on task will immediately update LX Eos' internal task. As long as on ground (not flying), the **new data** will be written into declaration of LX Eos flight recorder. The same will happen with pilot data. After take-off, the task synchronization will start working but the declaration in the flight recorder will remain unchanged (IGC rule).

## 7 LX Zeus and Colibri II

LX Eos and LX Zeus together create a very compact and robust system. All flight recording related settings are sent from LX Zeus and, in their relationship, LX Zeus is the master and Colibri II is a slave. This is why it is possible to install Colibri II in an inaccessible place (under/inside instrument panel), as long as the Colibri II position ensures good GPS reception. *It is essential that the Colibri II has version 1.93 or higher installed.*

Colibri II has an integrated ENL sensor.

### 7.1 Colibri II power management

Once the LX Zeus receives power, the Colibri II will automatically switch **ON** without any pilot action. **After landing** the Colibri II will **remain ON** as long as LX Zeus is powered. When LX Zeus is switched OFF, Colibri II will work for a limited time and switch OFF after approximately 5 minutes. Colibri II is permanently charged from LX Zeus and this ensures that the Colibri II battery will be always full. When, for some reason, battery power is lost on LX Zeus during flight, Colibri II will continue to record the flight for up to 15 hours.

### 7.2 Colibri II – LX Zeus interaction

Once a connection between Colibri II and LX Zeus is established both units start to communicate using a special LX protocol. The connection is established automatically without any pilot action.

#### 7.2.1 Commands and declaration transfer to Colibri II/Eos/Era

Every time the system is turned on the following data is sent to LX Eos:

- **Pilot data:** After initial setup on LX Zeus (also pilot 2<sup>nd</sup> name in a double seater configuration)
- **Recording interval**
- **Other data** related to flight recording with recording (Event repetition...)
- **Selected task:** the task will become declared

LOGGER LUKA	
<b>BASIC</b>	
Recording interval	5s
Event fix interval	1s
Event repetitions	20
Class description	
<b>EXTRA RECORDINGS</b>	
Extra recording 1	None

A long press on **the EVENT** button generates an event command that is sent to Colibri II. An event command can be sent also from the second seat.

#### Important!

**Any change** of task, will immediately update the Colibri II internal task. As long as it is on the ground (not flying), the **new data** will be written as a new declaration to the Colibri II flight recorder. The same will happen with pilot data. After takeoff the task synchronization starts working but the declaration in the flight recorder will remain unchanged (IGC rule).

#### Password 99999:

Password 99999 will delete all flights from Colibri II and LX Eos



## 8 LX Zeus and Flarm

Flarm should be connected to the FLARM port on the back of the LX Zeus; Flarm will also receive power via this port. If Flarm is connected to the aircraft power network via its own power input wires, a short-circuit problem does not occur due to a built-in diode. This separates both power supplies. Up to two Flarm external displays can be connected to ports marked as Flarm external display. The SD card slot on the LX Zeus front unit is directly connected to Flarm SD interface (valid for RB), without LX Zeus interaction.

The SD card may be used for:

- Flarm firmware update (Red Box or Mini Box)
- Downloading of flights stored on Flarm (Red Box or Mini Box)



On the rear of the LX Zeus 5.5 and 7.0 there is enough space to install LX Flarm Red Box as an integral part of the system. All connections are plug and play. It is also possible to install any other Flarm compatible devices.

Original Flarm (Swiss) can be used as well. LX Zeus will show objects from Flarm on the display and provide power for Flarm. Task declaration with pilot information is automatically sent from LX Zeus to any Flarm with a flight recorder once the task has been declared on LX Zeus.

The SD card slot cannot be used for Original Flarm (Swiss).

### **Note!**

In the case of LX Flarm Red Box there must be only 1 SD card inserted at once; either in LX Zeus micro SD card reader on the front of the unit or in LX Flarm Red Box unit, but not in both at once.

### **GPS signal priority**

If there are more units (LX Eos, Colibri II and/or Flarm) connected to LX Zeus, LX Zeus will use best GPS signal reception.

## 8.1 Flarm external displays

LX Zeus makes it possible to connect up to two Flarm external displays. Both connections are controlled from Flarm directly without any LX Zeus influence. LX Zeus system also provides 3V power for Flarm displays.

## 8.2 Task declaration into Flarm

In the case of an IGC approved version of Flarm, connected to Zeus Flarm port, an automatic declaration process is executed. The process is identical whether with LX Eos or Colibri II. This means that the current task and pilot data is sent to Flarm automatically.

The declaration process takes around 30 seconds. After the process is finished all LED lights on the Flarm display will switch off and the red POWER light will start blinking. This means that the process of sending task declaration to Flarm is complete.

### Declaration warning!

The SD card should be inserted into the SD slot *without any CONFIG (.cfg) file on the card!* If .cfg is on the card, then this file will have priority and the declaration will be wrong. Thus, there would be .cfg declaration instead of LX Zeus declaration inside IGC file so it will not work!

### Important!

Flight recording settings (recording interval...) will not be sent to Flarm, use SD card or Flarm Tool (see: [www.lxnavigation.com](http://www.lxnavigation.com) – support / manuals: LX Flarm update instructions).

## 8.3 Transferring files from Flarm

Transferring files from Flarm to a micro SD card is a very easy process. The micro SD card has to be inserted into the micro SD port, on the front of the unit (in case of LX Flarm Red Box). After the flight is completed, wait for around three minutes, then turn LX Zeus OFF and ON again. After switching on, a red POWER LED light on the Flarm display starts blinking. All other LED lights should be off. This means that all the flights that were not already on the micro SD card are now transferring to the SD card. After the red POWER LED light stops blinking the process is finished. The micro SD card, which will now contain all the flights from Flarm, can now be removed.

If the micro SD card has not been used for a while Flarm will automatically transfer all flights, that are not already on the micro SD card, from its internal memory to the micro SD card. If there are a lot of flights to transfer, the process may take up to 20 minutes! Flarm will always store a maximum 20 flights, so, if a 21<sup>st</sup> flight is recorded, then the oldest flight will be removed automatically.

### 8.4 LX Flarm RedBox / LX Flarm MiniBox update

LX Flarm RedBox and LX Flarm MiniBox can be updated via SD card or PC by using Flarm Tool software. Read update procedure at: [www.lxnavigation.com](http://www.lxnavigation.com) – section SUPPORT / MANUALS: LX Flarm update instructions.

### 8.5 Flarm PINOUT

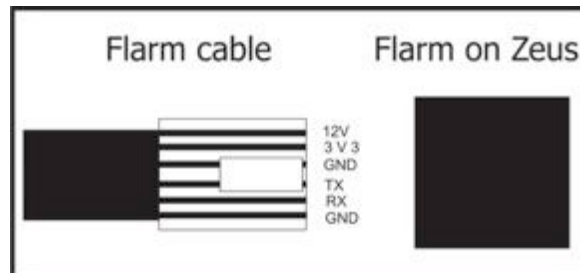

## 9 [LX Zeus and Garrecht](#)

Garrecht units can be connected to LX Zeus using supplied cables. A declaration to Flarm will be sent directly from LX Zeus.

Updating Garrecht units is not possible via LX Zeus. The connection schematic is shown below.

### 9.1 LX Zeus and Garrecht TRX-1090 ADSB / TRX-2000

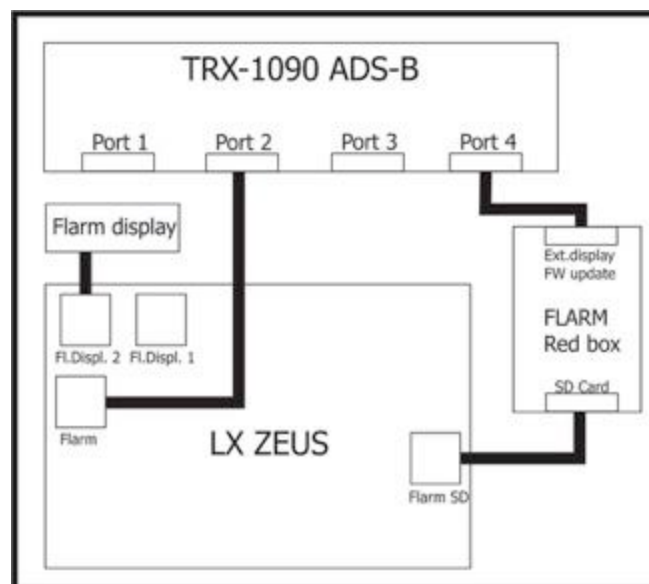

### 9.2 LX ZEUS and Garrecht TRX-1500

A special cable is needed for this connection. This cable can be ordered from LX Navigation under the following code: LX-TRX1500.

## 10 LX Remote Stick

LX Zeus can be controlled with a LX Remote Stick. The stick is a standard LX Navigation product, which does not differ significantly from sticks used by LX 7000/7007. Therefore, the upgrade of an existing stick is very easy. The Remote should be connected to one 485 plug and no special initialization is necessary. But note that only the short press function is supported with LX Remote Stick.

### 10.1 Use of LX Remote Stick

The plus and minus buttons have the same function as the Zoom rotary knob on LX Zeus.

The enter (✓) and escape (X) buttons have the same functions as pressing Zoom and Volume rotary knobs.

#### Zoom IN/OUT:

Use buttons Minus and Plus on the LX Remote Stick.

#### Select screens (APT, TP, TSK):

Use APT button and press it until you will have the indication on the top in left corner of APT, TP, TSK.

#### Select second page:

Use SUB button on LX Remote Stick.

#### Change information at second page between info and vertical profile:

Use 1-4 button, you can also Zoom In/out with Minus / Plus

#### Change MC:

- Press MC.
- Press Minus / Plus button.
- Press X to go back to navigation.

#### Select TP, APT:

- Press X button.
- Use MINUS to go to Country, Name or Sort by Distance filter.
- Use Check/confirmation button to select the filter (*Example Name filter: press Check, press Plus to change the character and press confirmation, go down with Plus and select the TP or APT with Check button*).

#### Select in TP/APT/TSK mode

Pressing the “check” button will activate different screen buttons. The selected screen button will be highlighted in yellow. Moving to a different screen button is done by using + or – buttons on LX Remote Stick. To select a highlighted button click the “check” button and the next dialog will open.

### 10.2 LX Remote Stick on second seat

LX Remote Stick for second seat is the same as for the first seat (no different firmware unlike with the LX 7000/7007). The unit should be connected to the second seat unit using the 485 bus.



## 11 LX Joy

### 11.1 General

LX Joy is an ergonomically designed, leather covered remote stick handle for gliders. As seen by the pilot, it consists of 5 buttons and a navigation switch on the front side, one button on the rear side, a built-in electronic circuit and wiring.

The internal diameter of the bore can be 19,1 mm, 20,1 mm or 24,3 mm. It is important to point out the dimension when ordering your remote stick. (If the glider type is specified when ordering LXN will know what size is required)

#### **NOTE!!**

In order for LX Zeus to work with LX Joy, the software version on LX Zeus should be at least **3.2.2** or higher.

### 11.2 Button description

#### **NORMAL MODE (LED OFF)**

(as seen by the pilot)

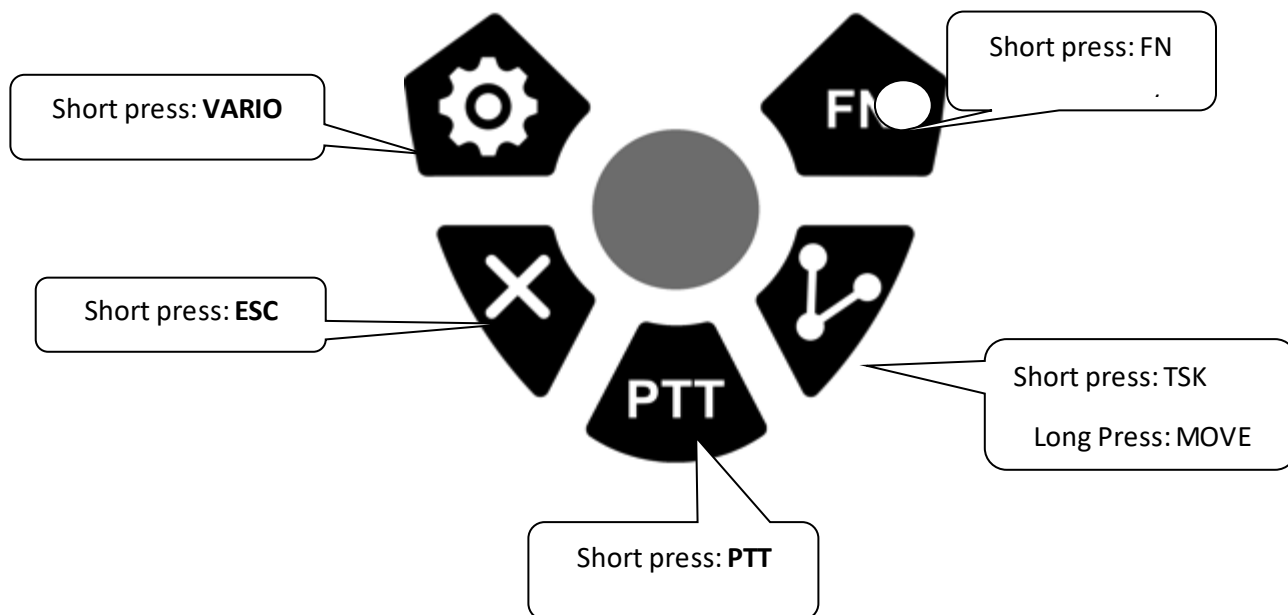

LX Joy middle button:

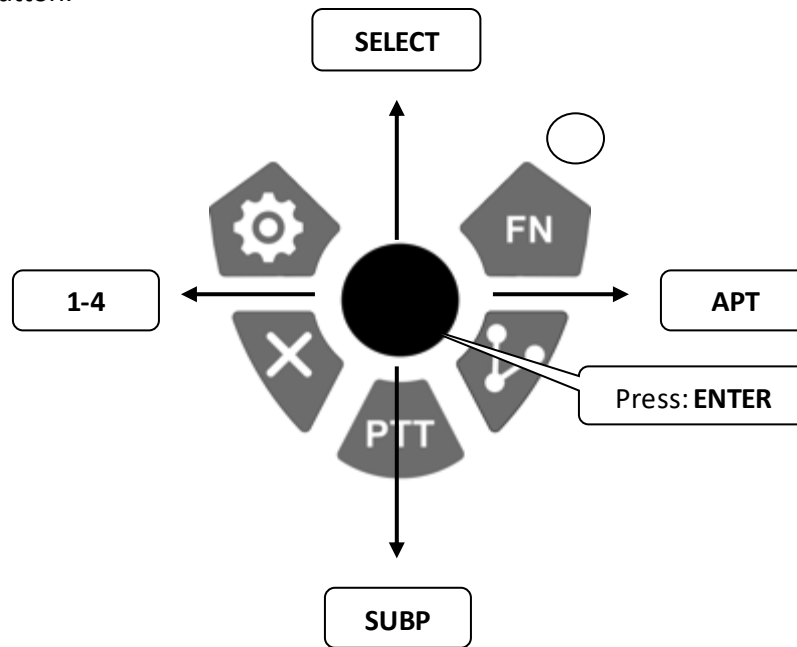

**ZOOM/VOLUME MODE (LED GREEN)**

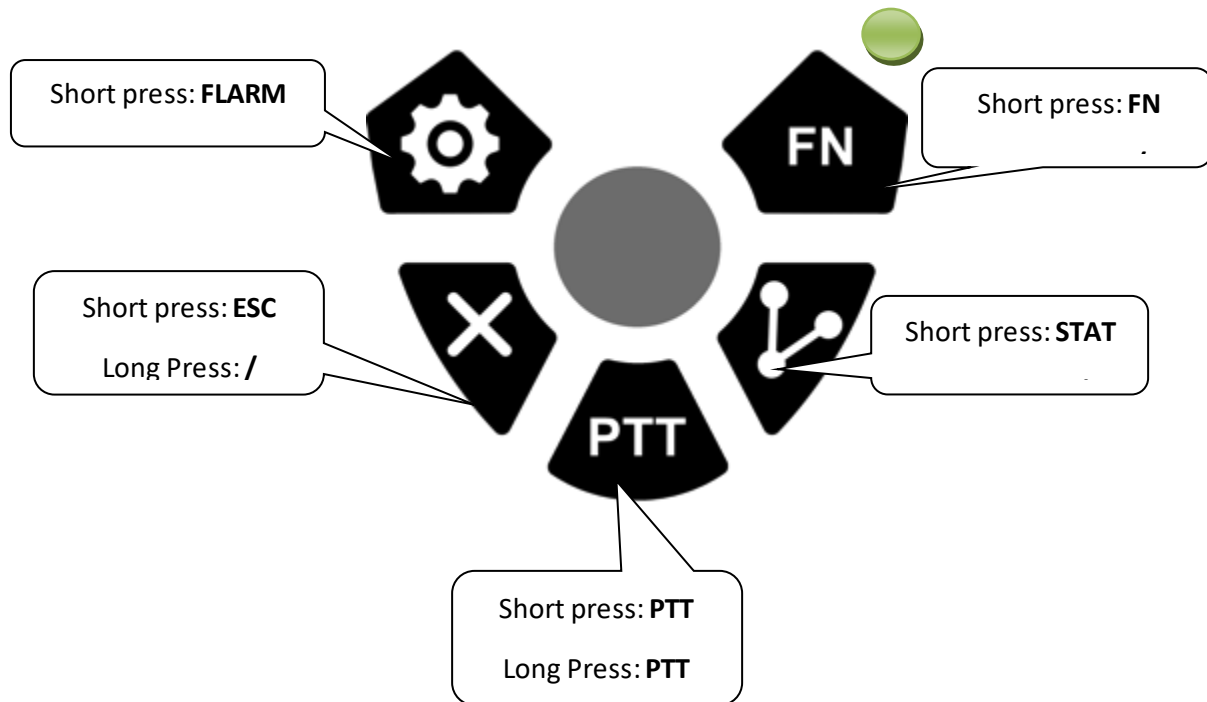

LX Joy middle button:

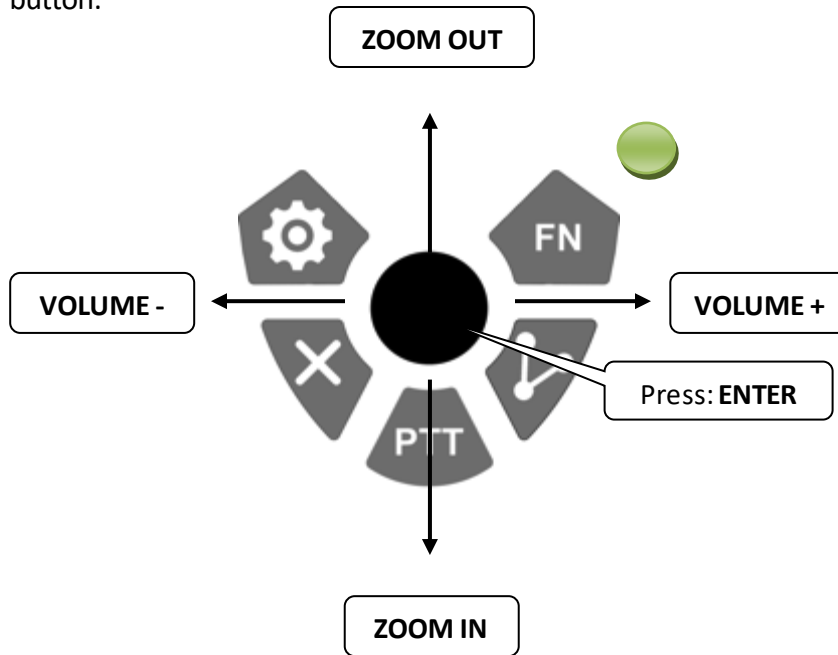

**PAN MODE (LED RED)**

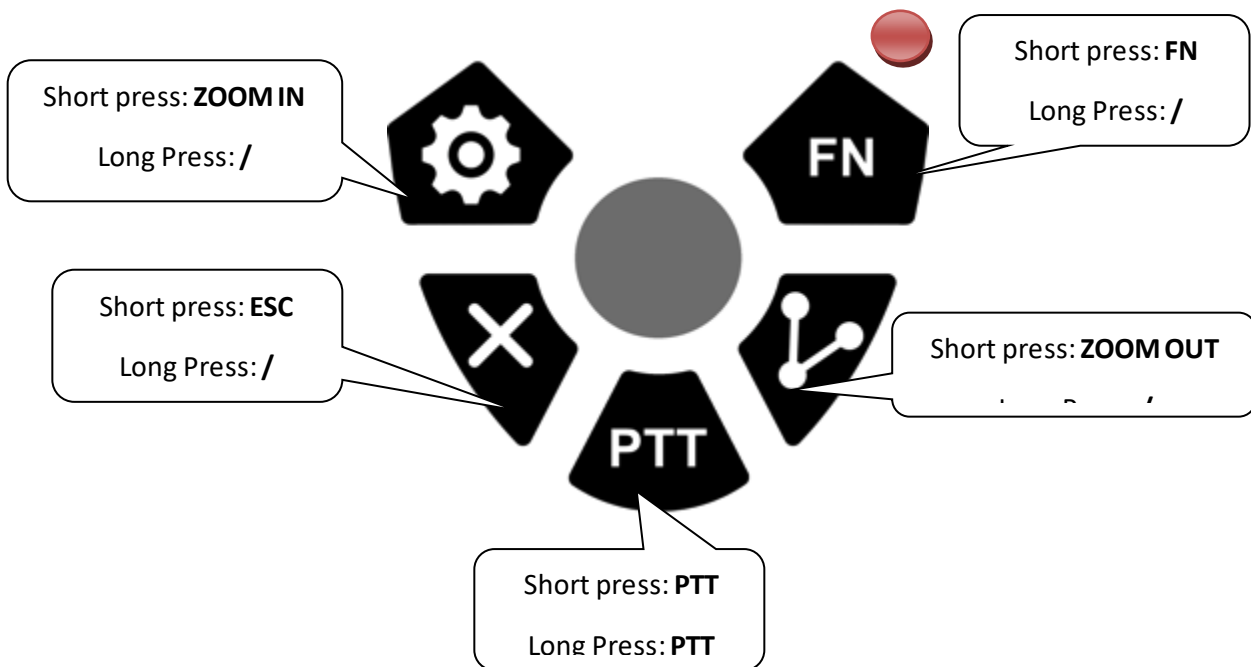

LX Joy middle button:

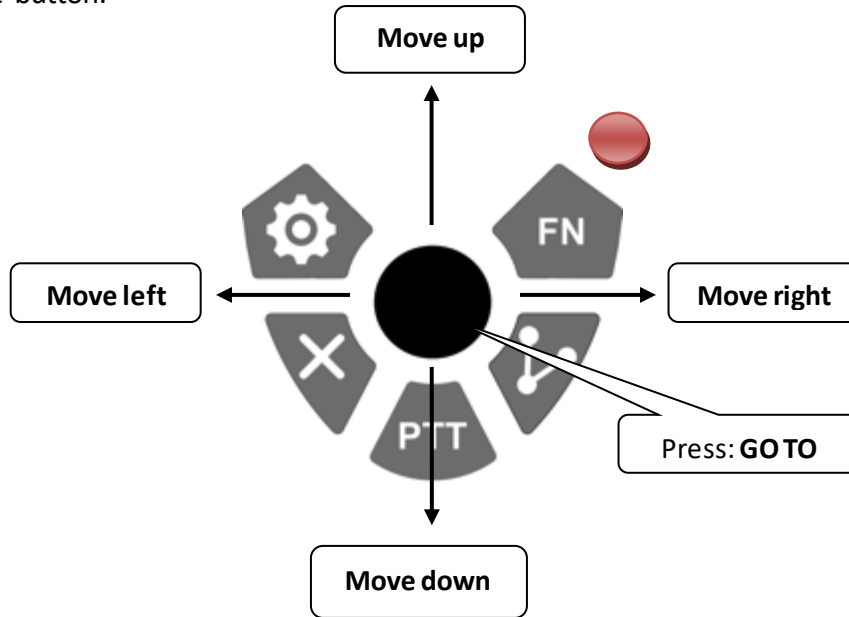



## 11 [Second seat unit](#)

The second seat device is connected to the master unit via the **CAN bus** (it does not matter which connector on LX Zeus is used). The connection includes power and data communication for the second seat. This means that the second seat unit does not need an additional power supply. An external toggle switch makes it possible to switch off the unit during single pilot operation. Otherwise all commands are the same as for the main unit. GPS inputs on the second seat unit do not work and so **DO NOT** connect GPS sources to the sockets on the second seat (Colibri II, Flarm). Also, the Flarm display connectors are not used.

All LX Zeus sizes (2.8, 4.3, 5.5 and 7.0) can be used as second seat units. The first and second seat units can have different screen sizes.



### Note!

Flarm, LX Eos, Colibri II, Voice module and Magnetic Compass should be connected to the first seat.

### 1.1 [Connecting Vario Indicator and LX Remote Stick](#)

The vario indicator (this cannot be a USB D unit) and/or LX Remote Stick for second seat should be connected to the 485 bus of the second seat device. Both vario indicators and LX Remote Stick are compatible with existing units connected to LX 7000/7007. The Remote doesn't require any setup.



#### 11.2.1 [Secondary Vario Indicator setup](#)

The function of the vario indicator connected to the second seat unit should be defined under Setup > Indicators on second seat LX Zeus. Indicators (upper and lower indicator) on the second seat vario can be adjusted from the LX Zeus second seat. Automatic SC switching and external switch mode cannot be adjusted from the second seat unit.

### 11.3 Connecting LX Eos repeater to LX Zeus on second seat

To connect a LX Eos repeater to a LX Zeus in the second seat, simply connect units with the CAN cable, which is supplied with LX Eos repeater unit, using the CAN ports on both units.



### 11.4 Interaction LX Zeus – LX Zeus Second seat

LX Zeus fitted in the front seat and LX Zeus situated in second seat are two units with identical HW configuration, but the second seat unit is prepared to play a slave role in most cases. (The initialization of the second seat system is done during the production process at the factory.) The units are connected via a CAN bus using a single CAN cable. In general, the second seat unit does more or less an independent job but it receives all navigation and air data from the master. All secondary interfaces relating to the second unit, such as a LX Remote Stick, etc., should be connected to the second seat unit.

The following parameters are exchanged between both units:

Item	To first seat	To second seat	Automatic	Manual
Sec. pilot name	Y		Y	
Sec. pilot mass	Y		Y	
TSK /TP/APT exchange	Y	Y		Y
Team code	Y	Y		Y
Logger setting	Y		Y	

#### 11.4.1 TSK / TP / APT exchange

The TSK / TP / ATP information can be exchanged from first to second seat and vice versa. The pilot, who wants to send the task / turnpoint / airport, should press the Zoom rotary knob and then select screen button Send task / Send TP / Send APT. The other LX Zeus will receive it immediately. Also, LX Zeus will send the whole task with its statistics, moved zones, limitations etc. When a task is sent from second seat to first seat the declaration is also sent to LX Eos, Colibri II.

#### 11.4.2 Downloading flights from Second seat

Downloading flights is possible only from the first seat unit.

## PART THREE – Flying

### 12 Flying with LX Zeus

It is recommended that the unit is set up for every flight before take-off to ensure a stress-free and enjoyable flight. This is especially important before any contest, record attempt or badge flight.

#### 12.1 Flight preparation on the ground

It is suggested that the following be checked:

- Database status
- Prepare task (use new or edit options, or select imported task)
- Selected pilot profile with important settings

##### 12.1.1 Before take off

- Switch the unit ON at least **3 minutes** before take-off (this will ensure sufficient GPS reception and will create a base line for the baro trace)
- Select correct **pilot** (there will be many settings specific to each pilot)
- Check whether the task entered is correct by using **Task edit**
- Declaration: A task selected and active before take-off will be **declared** automatically to connected flight recorders (LX Eos/Era, Colibri II and/or Flarm)
- Switch on **second seat** unit if in a double seater

### 12.1.1.1 Initial setup procedure

LX Zeus requires the User to select **take off elevation** during the Initial Setup procedure. The elevation set must be correct. If the take-off point is not in the database, then the elevation of the closest Airfield could be used. If the airport database is empty, or there is no closest airfield available, current elevation could be used with QNH set at 1013 hPa but if this doesn't match the elevation of the actual take off point then it should be changed. The User can also set pilot (profile settings), active polar and set ballast. Settings inside Setup menu can always be changed (apart from elevation setting).

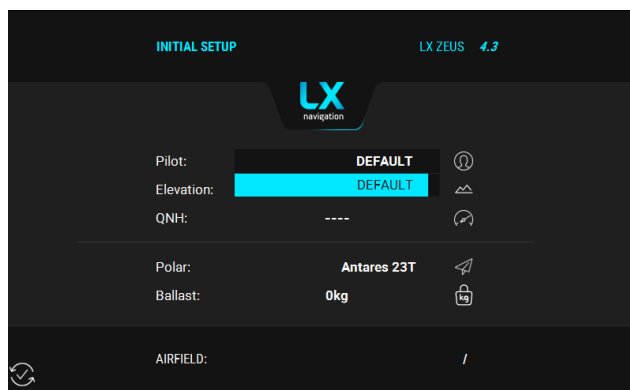

On the second seat unit, it is possible to select only the pilot doing the flying; other data can only be selected on the first (main) seat unit.

Once the elevation has been entered, LX Zeus will suggest that the current QNH value be used. If the User knows the QNH of the day it should be entered. If not, then an approximate value should be entered. QNH can be changed by pressing the VARIO button. After the input of QNH on the ground the pilot will be able to adjust altitude reading during flight if the QNH changes.

**Note!**

QNH setting doesn't replace **setting of elevation** during booting which should be carried out every time otherwise the unit will not switch to navigation mode. QNH setting isn't obligatory and may be omitted.

### 12.1.1.2 Task declaration process

The task declaration process is fully automatic and doesn't need any pilot interaction. **The planned task and pilot data** is written into all connected flight recorders immediately after selection. The declaration data will not change during flight, even if task data changes due to the select or edit process (IGC rule). The action is accompanied by a message on the display.

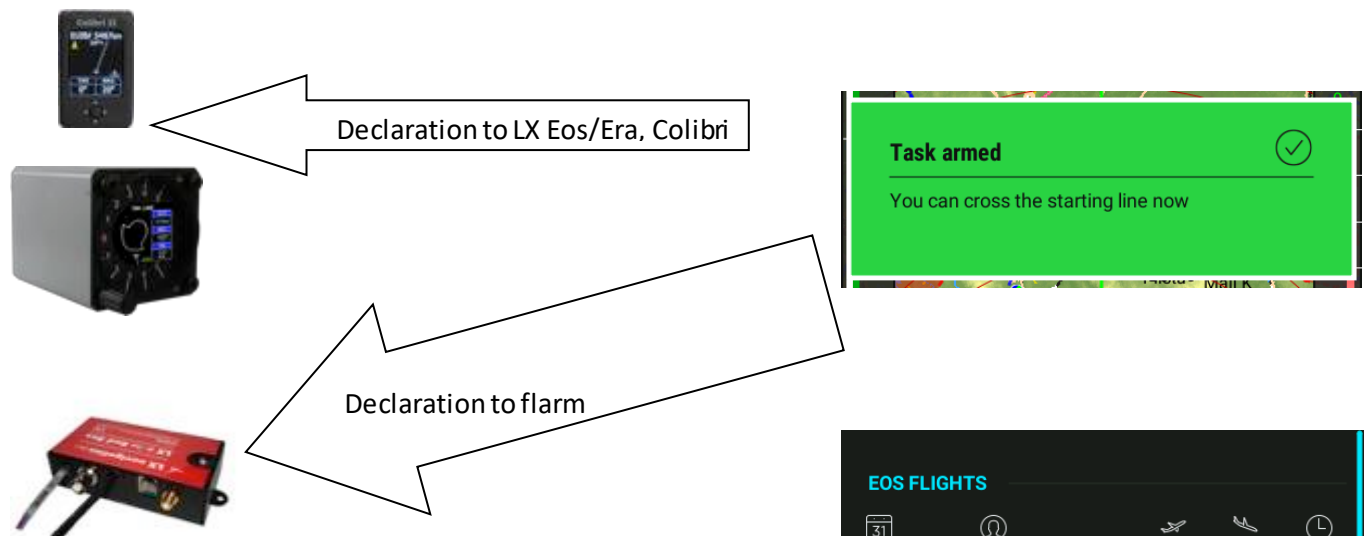

### 12.2 During flight

The LX Zeus HW and SW concept is combined in such a way that pilot input during flight is cut down to the minimum, enabling the pilot to give full attention to piloting. It is important to point out that there are many shortcuts which enable direct and fast access to most important functions. If confused, just wait for around 15 seconds and the Auto close feature should close the current dialog. A clear indication that the unit is in flying mode can be determined by checking that the Logbook page is replaced by the Statistics page when the **STAT** button is pressed.

EOS FLIGHTS				
Date	Task	Start	End	Duration
23.11.2016	LUKA	14:54	14:58	00:04
23.11.2016	LUKA	11:29	11:46	00:18
22.11.2016	LUKA	15:04	01:00	09:56
22.11.2016	LUKA	11:01	11:06	00:05
25.09.2016	EISBERG LSV	11:53	11:54	00:01
09.09.2016	EISBERG LSV	11:31	16:53	05:22
08.09.2016	EISBERG LSV	13:16	18:33	05:17
08.09.2016	EISBERG LSV	13:16	13:16	00:00
08.09.2016	EISBERG LSV	11:11	13:16	02:05
07.09.2016	EISBERG LSV	11:48	16:30	04:42

### 12.2.1 Set MacCready (MC), Ballast, Bugs and QNH

After a short press on the VARIO button a new window will appear – MacCready. The menu will give options, to adjust MacCready (MC), Ballast, Bugs and QNH. Setting MacCready, Ballast and Bugs will influence the glider polar and MC speed, sink speed, cruise speed, as well as the overall efficiency that will also be changed.

Entering a Bugs setting will decrease the efficiency, which will affect the final glide calculation.

Example:

- Efficiency is 30.
- Bugs setting is 10%.

Equation:  $F_{bugs} = f \times (1 - bugs \text{ [fraction]})$

$$= 30 \times (1 - 0.10) =$$

$$= 30 \times 0.9 = 27$$

#### QNH setting:

The pilot should input the actual QNH value of the airport being used for take-off during the initial setup process. This action should be carried out on the ground; after take off the menu will not open any more. After input of QNH on the ground the pilot will be able to adjust the altitude reading during flight, if the QNH changes.

### 12.2.2 Statistics

The statistics page will open after a press on the STAT button.

The statistics page offers the following statistics data:

- **Thermal analysis:** Two types.
- **OLC:** Calculation of OLC distance, score etc.
- **Baro:** Shows baro trace from take off until present position
- **Task:** Presents task statistics data divided by legs
- **Route:** Shows task and flown distance
- **Timer:** Starts timer

The statistics page colour structure can be adapted to suit a pilot's personal requirements. This can be done under: **Setup > User Interface > Statistics colours.**

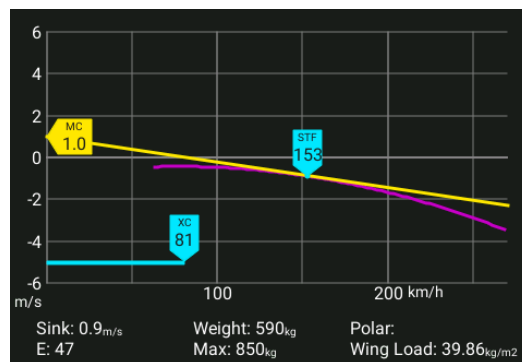

#### Note!

QNH setting doesn't replace **setting of elevation** during booting; this should be carried out every time otherwise the unit will not switch to navigation mode. QNH setting isn't obligatory and may be omitted.

#### Note!

When the task has not been started yet, the statistics data is limited to take-off and flight duration.

#### Note!

If the task consists of more than three legs, use **zoom** to select legs of interest.

**End Flight** function will close the flight so don't use it during flight. Once End Flight has been commanded the flight will end and the flight recorder (LX Eos/Era and Colibri II) will be forced to stop flight recording and create an IGC file.

### 12.2.2.1 Thermal Analysis

There are two pages of thermal statistics, which are selectable by pressing the screen buttons:

- **Thermals 1**
- **Thermals 2**

#### Thermals 1

Every column depicts a thermal. The column is sliced into various colours and widths. The colours are blue, yellow and red. These colours depend on the current MacCready setting. If the thermal strength is below the MC setting, then the column is blue, if it is above then the colour is red. The yellow colour is around the MC setting (plus / minus 20% of MC).

#### Thermals 2

This page shows all thermals of the flight; as a reference the actual MC setting is shown also. The value depicted corresponds to average thermal vario of an individual climb from entering to leaving the thermal. The thermal is only shown after a gain at least 100 m of altitude. The dotted red line through the columns shows the MC setting. This assists in determining a good MC setting.

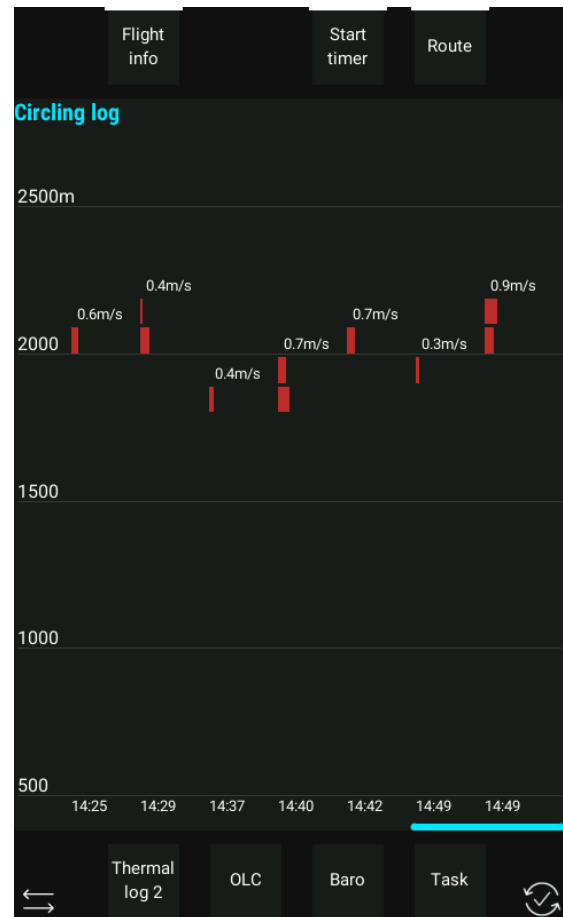

### 12.2.2.2 OLC Calculation

OLC calculation is a calculation of OLC points according to OLC rules. The current rules can be checked at:

<http://www.onlinecontest.org/olc-2.0/gliding/cms.html?url=rules>.

In general, the scoring software selects a departure point within the unpowered part of the flight with up to 5 waypoints (turn-points) and a finish point in such a way that the following two conditions are fulfilled:

- The raw point score (1 point per km) from the departure point via all waypoints to the finish point is a maximum.
- The departure altitude is not more than 1000 m higher than the finish altitude.

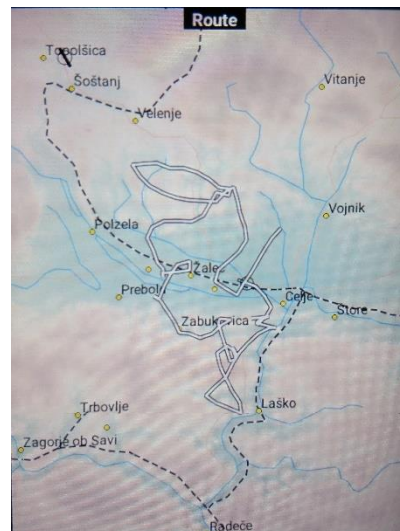

To stimulate “area“ flying a FAI bonus is granted. For this purpose, the scoring program checks whether FAI triangles can be fitted into the flight route and, if so, determines the largest such triangle for calculating the FAI bonus.

There are three NavBoxes showing how many OLC kilometres have been achieved so far. One is labelled OLC and shows the kilometres made to current point in the flight. The other one is labelled OLC HOME and shows how many kilometres will be made if a return to the take-off point is achieved. The third NavBox is OLC speed, which indicates the speed over the whole OLC distance flown.

### 12.2.2.3 Baro trace graph

A baro trace from take-off to the current position will be opened by pressing the button next to **Baro**. Customisation of colours is possible at **SETUP/USER INTERFACE/ STATISTICS COLOURS**.

### 12.2.2.4 Task Statistics

This page will open after pressing Task screen button. Task statistics are shown for the whole task and for individual legs.

- **Speed:** Average speed
- **Dist:** Flown distance
- **Dur:** Duration
- **V Avg:** Average value of vario in thermals (circling)
- **Circ:** Percentage of time circling (not flying straight)

#### Note!

Use Zoom rotary knob to scroll through the legs, as the display is capable of showing only 4 legs at once.

Statistics are also available on 1<sup>st</sup> subpage on Task (TSK) navigation page.



### 12.2.2.5 Route

Route option is a feature showing the track already flown and the current task on the map. This enables the pilot to see how precise the flying was and where detours were made.

### 12.2.2.6 Timer

To use a stopwatch, the timer function can be used which is located in Statistics. Timer manipulation is as follows:

- Select Start timer screen button and timer will start.
- Stop timer by pressing Stop timer screen button.
- Reset timer.

	Flight info	Start timer
	Task	Leg 1
Speed km/h	---	
Dist km	0.0	
Dur	0:00:00	
V Avg m/s	0.0	
Circ %	0	

	Flight info	Stop timer
	Task	Leg 1
Speed km/h	---	00:04.5
Dist km	0.0	
Dur	0:00:00	
V Avg m/s	0.0	
Circ %	0	

### 12.2.3 Follow me

The Follow me function can be accessed by long pressing the Vario/Flarm button (the Flarm menu), selecting the Flarm object we want to follow using the zoom rotary knob and pressing the TSK/Move button, which selects the highlighted Flarm object.

### 12.2.4 Special functions

#### 12.2.4.1 Event function

This function is active only if LX Eos and/or Colibri II is a part of the system. A long press on the **EVENT** button will send a command to connected flight recorders to activate the event function. This means recording in shorter intervals as a default for a limited time (default: event fix interval: 1s; event repetitions: 20). Event settings are under **Setup > Logger**.

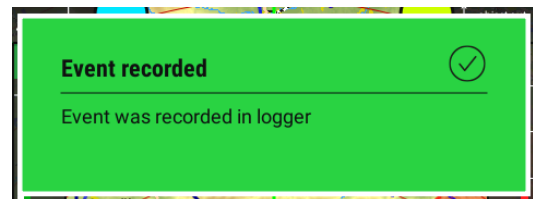
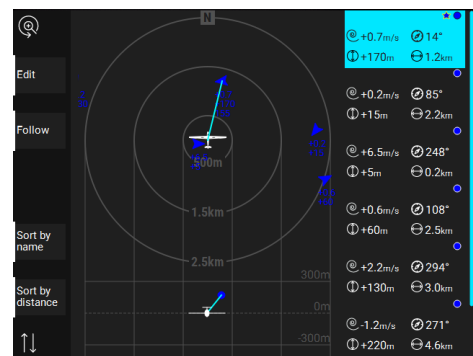

### 12.2.4.2 Marker setting

If the pilot wants to mark a position of interest, for example a suitable out-landing place, thermal hot spot...), this can be done by activating the **Marker function**. The process is very simple and doesn't require much attention by the pilot.

To mark a position the pilot should do as follows:

- On **TP** navigation page, press **Zoom** rotary knob
- Select screen button **Add marker**

The marker is shown as a yellow triangle on the map. Only one marker can be active at any one time. To set a new one simply repeat the procedure.

The marker is stored as user turn-point designated as **#MARKER**. If edit TP function is used the **#MARKER** can be converted into a normal TP. **#MARKER** can also be deleted after using the **Delete TP** command. To navigate to **#MARKER** point, simply select **#MARKER** under Select TP dialog.

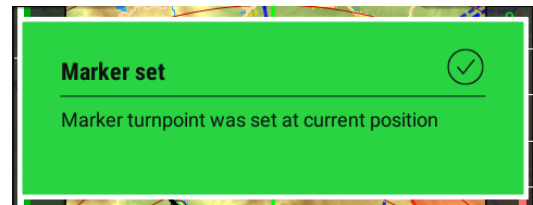

**NOTE:**

**Marker function is possible only in TP navigation**

### 12.2.4.3 Pan mode

It is possible to move the position on the map using the Volume and Zoom rotary knobs. Pan mode is available on all three navigation pages (TP/APT/TSK). During the flight, the tail and Flarm objects are displayed on the map in pan mode.

To activate the mode, press button SELECT and choose Pan mode screen button. It will then be possible to move to the desired location on the map and, if GO TO is used, the system will start navigation to a selected position on the TP navigation page. The name of this selected point is displayed as the current time.

A task in Pan mode can be created by accessing Pan mode from the TSK navigation page. For more information see chapter *Creating a task in Pan mode*.

### 12.2.5 Task Start

Task start is quite a complex procedure, especially with a high density of gliders where many of them intend to start at nearly the same time. When the pilot intends to cross the start line, a simple operation should be carried out:

**Press on TSK button and press ARM screen button.**

A message **ARMED** will appear on the display. The word Armed will remain until the **first line crossing**. After crossing the line the task will start automatically without any further pilot interaction.

**Note!**

ARM command can be executed at any time, even on the ground.

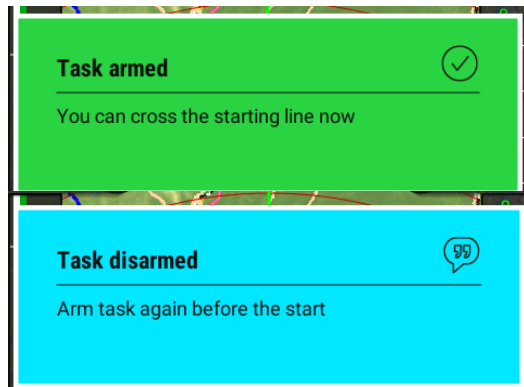
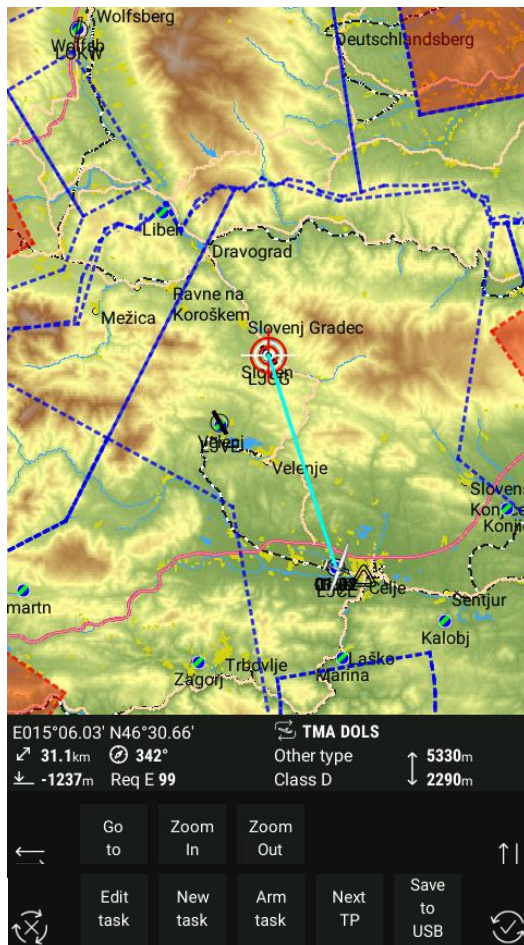

If the start line is crossed multiple times, the time of the last valid start will be used for statistics calculation. Every next start is also displayed by a green message Task started at...

Under Settings > User interface > Track/destination settings the pilot can choose whether navigation is aimed at the zone center or the zone closest point.

Disarm function will disable the Arm command.

**Note!**

In the event that the pilot crossed the start line and forgot to execute ARM before that, execution of **NEXT TP function** will solve the problem. Navigation to the first turn point will then be offered and the statistics page will become available. LX Zeus will find last valid start line- cross and use it for statistics.

*12.2.5.1 Start Conditions / Limitations*

Some competition rules prescribe limitations (restrictions), which should be respected before the start and also while crossing the start line. After a short press on TSK/MOVE screen button, Limitations will appear. Select Limitations screen button to enter limitation setup menu. Limitations are divided to:

- Gate time
- Before start
- Start conditions

Gate time sets the time when the start line will be opened. Calculated time will be time set on LX Zeus (UTC or UTC offset time). LX Zeus time is by default set to UTC time. Time offset can be changed under Setup > Locale > UTC offset.

Below start altitude and time can be set. The glider should be below the selected altitude when starting.

Start conditions can be limited to start altitude and ground speed.

A limitation indicator will appear on the screen (only on TSK screen). First the pilot needs to add the Limitations indicator to the screen by modifying the TSK layout. Go to Setup > Layout and edit TSK navigation page.

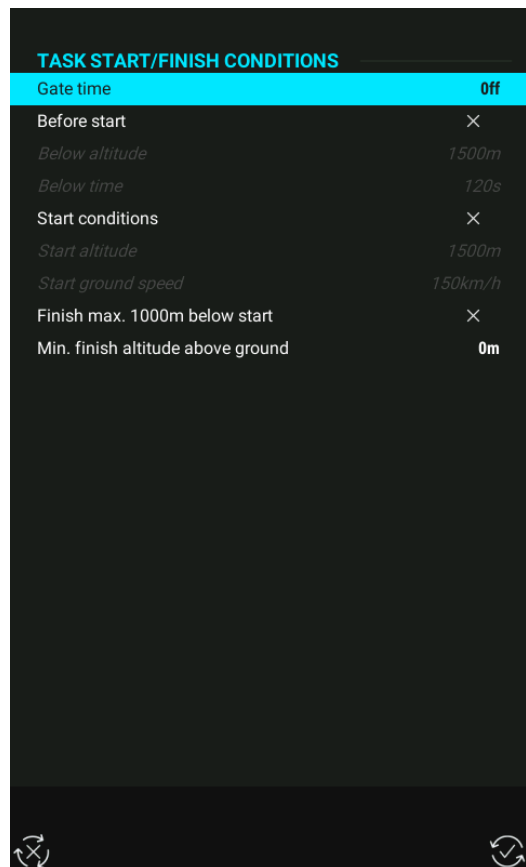

*12.2.5.2 Task Restart*

If the pilot decides to restart the task, having already started, it is possible to do this by executing the **Restart** function. It is accessed by pressing TSK/MOVE button and then pressing the Restart screen button. After pressing Restart, the task will be reset (doesn't matter on which leg) and a new start can be performed. Also, the task statistics will be reset.

**Note!**

After Restart, the unit will change immediately into **ARM** status, which means ready for next start.

### 12.2.5.3 Restart Leg

Restarting a leg is possible during an active leg. After pressing the TSK/MOVE button the screen button Restart leg will be displayed.

### 12.2.6 Task Finish

A Task finish will be detected after the glider has passed the finish line / cylinder. The event will be displayed by a very clear message showing the achieved task speed.

### 12.2.7 Flying Assigned Area Task (AAT)

AAT (Assigned Area Task) is one of the common task types used on competitions. The basic idea is to set relatively big sectors around turn-points which makes it possible for the pilot to decide how deep into the sector he will fly. The main objective is to have the highest possible average speed, while the pilot chooses his own route, but limited by the given AAT turn-point sectors.

Create an AAT:

- Press TSK/MOVE button
- Press New task or Edit task screen buttons
- **Set Task time. This must be set for a valid AAT**
- Set sector geometry – go to TP, select Zone, edit R1(10 km and more) and A1 according to task sheet
- Move function: makes it possible to adapt AAT distance and also get information about important task parameters: remaining distance, required speed etc.

Move function is also available after a long press on the TSK/MOVE button. Use Zoom and Volume rotary knobs to

#### Note!

If task time is not entered, some statistics data may not be available: task delta time, task remaining time etc.

When flying a task, and when a new task TP becomes active, the same TP becomes a navigation point on TP navigation page.

#### Note!

If a sector radius is bigger than **10km**, the unit will recognize this as an AAT and will set manual change over to next turn-point (Auto next is disabled). Using smaller sectors (<10 km) on AAT, the system will request a manual setting of **No** Auto next.

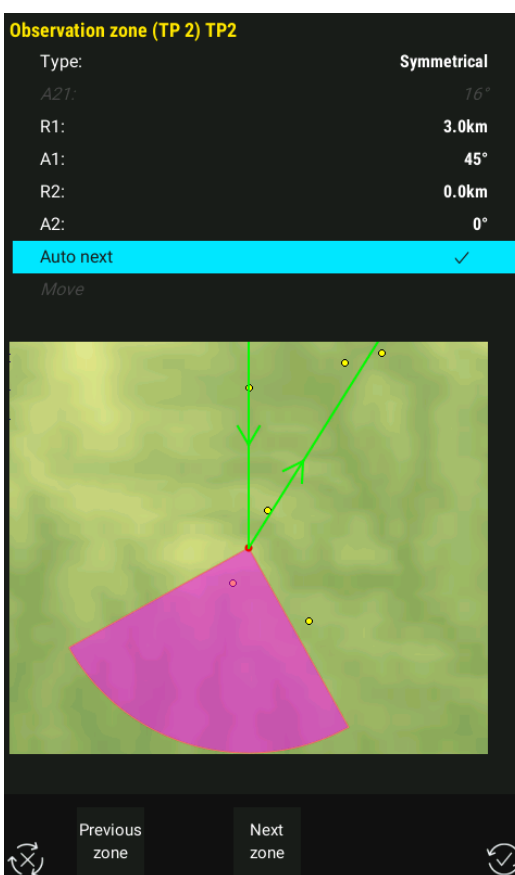

### 12.2.8 Final glide (FG) calculation

The final glide (FG) calculation is based on the following inputs:

- Actual MC settings.
- Wind.
- Polar.
- Bugs.
- Ballast.
- Safety altitude (reserve).

The final glide is available as an indicator on the navigation page and a NavBox. Different colour/size positions for the final glide indicator can be set. By default, there are two FG indicators: The white FG indicator will always display FG at a selected MC value. Yellow FG indicator displays FG with MC 0. “-” means the glider is below glide path, while “+” means it is above glide path. Depending on the settings of altitude units, this indication is in meters or feet. Final glide is visualized on the 1<sup>st</sup> subpage where both final glide calculations are shown against a terrain profile. In the case of flying a task, the final glide profile will be calculated to finish point.

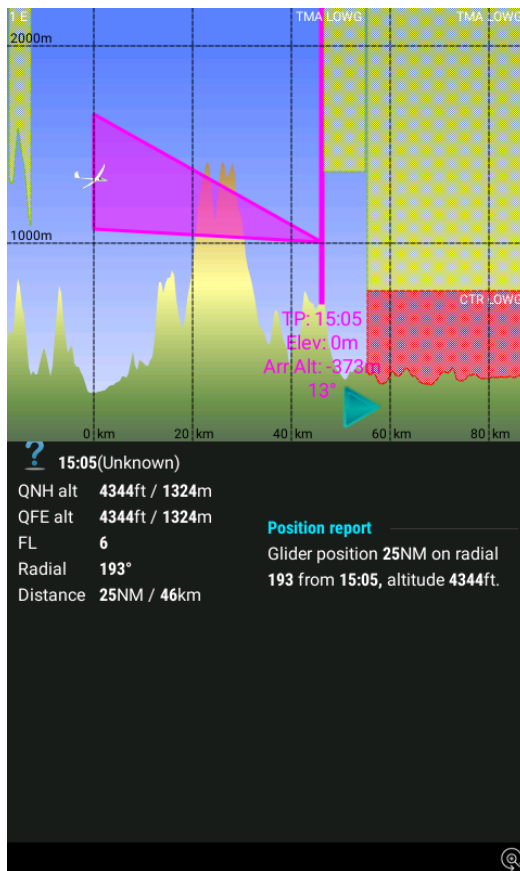

#### Note!

In Task mode, the final glide is calculated from the current position to the finish via all unflown turn-points.

### 12.2.9 Finish line crossing

In some competitions, long finish lines or finish cylinders may be stipulated. LX Zeus is continuously calculating all parameters and statistics based on **the shortest way** to reach the finish and therefore it offers the shortest distance to reach it. This distance is used in all calculations (FG, TDT, etc.).

### 12.2.10 Thermal assistant

The thermal assistant analyses the thermal while circling. The size of the dot indicates the strength of the thermal – a bigger dot means stronger lift.

DOT colour:

- Red colour means vario values are above MC
- Blue colour means vario values are below MC
- Yellow dots show vario value at +/-20% of MC setting
- White dot shows the maximum climb rate of the thermal

**Note!**

If the indicator shows mostly red, then MC should be increased, if colour is mostly blue, then the MC setting should be decreased.

A symbol of a glider will appear on the right or left side of the circle. If the glider is on the right of the circle it means that it is circling to the left and the thermal is on the left side.

The user can select a zoom level to which the map is switched once circling has been detected.

This can be changed in Setup > User interface > Map settings.

In Setup > Layout the size and position of a thermal assistant can be customized. Default position is in the lower left corner below the IAS indicator.

**12.2.11 Flarm management**

The unit will show Flarm objects if a Flarm unit is connected to the system. There are two ways to see Flarm objects on LX Zeus:

- Objects displayed on the map as glider icons for gliders, airplane icons for powered planes and circles around you for nondirectional objects.
- Another way to see Flarm objects is via Flarm radar, which can be opened after a long press on the VARIO/FLARM push button. There is no limit to the number of Flarm objects displayed on LX Zeus.

A default colour can be set in Settings > Flarm. There are some additional settings that are related to displaying Flarm objects on the map. Different colours for objects that are above and below can also be set.

Alongside Flarm objects there is information about relative vertical distance and current climb rate. Climb rate data is not accurate so it should not be trusted.

If FlarmNet list is used, or if objects are customised, it is possible to also see Call signs of Flarm objects.

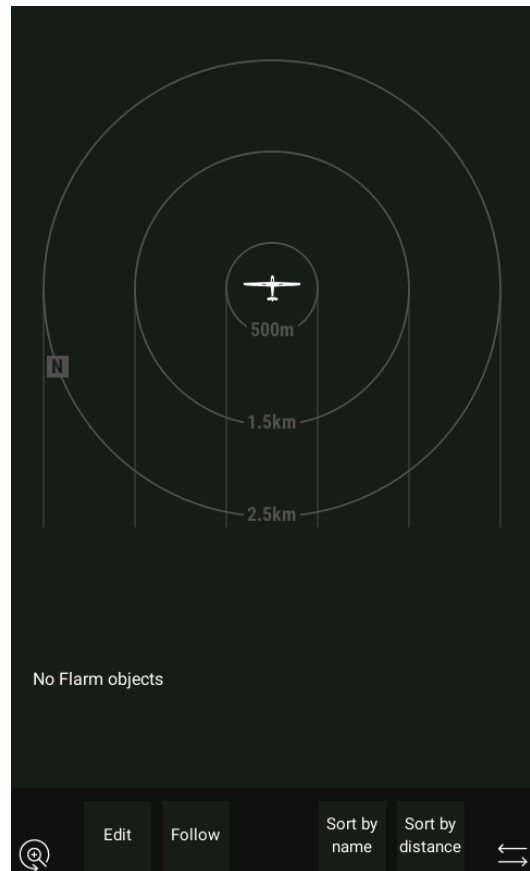

On the Flarm radar page, objects can be customized (Call signs and colour). Three objects can be selected at once. The zoom level on the Flarm radar page can be changed by rotating the Volume rotary knob.

Procedure for customization:

- Long press on VARIO/FLARM will open Flarm radar page
- Rotate Volume rotary knob to adjust Zoom on Flarm radar page
- Rotating Zoom rotary knob will move an orange frame to select/store 3 objects on the bottom in a box
- Press Zoom rotary knob to select the object in range
- Long press on Zoom rotary knob will open a dialog with more details about selected object
- Rotate Zoom rotary knob to select the details you want to see or modify
- Press Volume rotary knob to go back to Flarm radar page

12.2.12 Attitude and heading reference system (AHRS)

An artificial horizon (AHRS) box can be connected to LX Zeus simply by connecting it via a CAN cable (Plug and Play). It can be connected to the first or second seat LX Zeus.

There are 2 ways to display AHRS on LX Zeus:

- 3D Synthetic vision displayed together with split screen map. Press SUBP button to access 2<sup>nd</sup> subpage. One can also set it so that 3D view covers the whole screen (under Setup > User interface)
- AHRS Indicator on the map. Add/edit/move AHRS indicator can be done Under Setup > Layout

If AHRS is connected to the system, it is possible to see AHRS on LX Eos or NavBox units connected via the CAN.

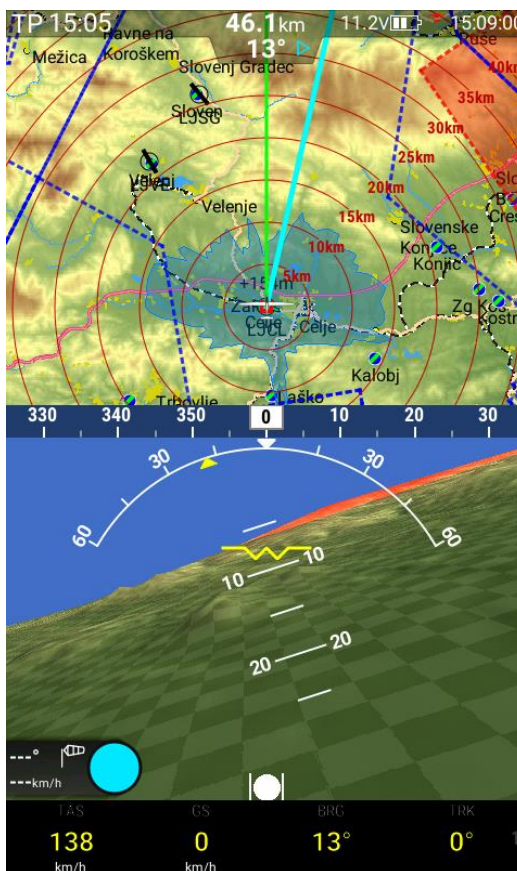

**Important!**

Orientation of AHRS box is very important. It has to be installed as it is shown on the label on AHRS unit (little white glider icon)

Pressure connection:

- Pst – connect static pressure
- Ptot – connect dynamic pressure



### 12.3 After landing

The Zeus should be kept ON for a few minutes after landing in order to ensure that a baseline for the baro trace is generated. There will be a small window showing: **Flight will end in xx:yy** this being the time left until the flight recorder stops recording. When flight recording is complete the recorders will start to calculate the security signature of the IGC file (Calculating security message). When this message disappears, it means that connected flight recorders have stopped recording and that the IGC file is ready for download. If the STAT button is pressed the Logbook will be accessed instead of flight statistics. The Zeus can now be switched off and/or the flight downloaded.

#### 12.3.1 Downloading flights

It is possible to download flights from LX Zeus directly from any or all connected flight recorders (LX Eos/Era, Colibri II, Flarm).

Flights from LX Eos and Colibri II can be downloaded to a USB stick. Flarm flights are downloaded with a SD card.

The flight file structure meets IGC standards and therefore such flights can be evaluated by any program that accepts. IGC data format.

In the case of a Flarm (RB IGC version) connected to LX Zeus, its flights will be stored to the inserted micro SD card without any LX Zeus interaction. The procedure is automatic, and the new flight will be stored **after next power on**.

**Note!**  
In the case of LX Flarm Red Box, it is **only** possible to download flights **by SD card**

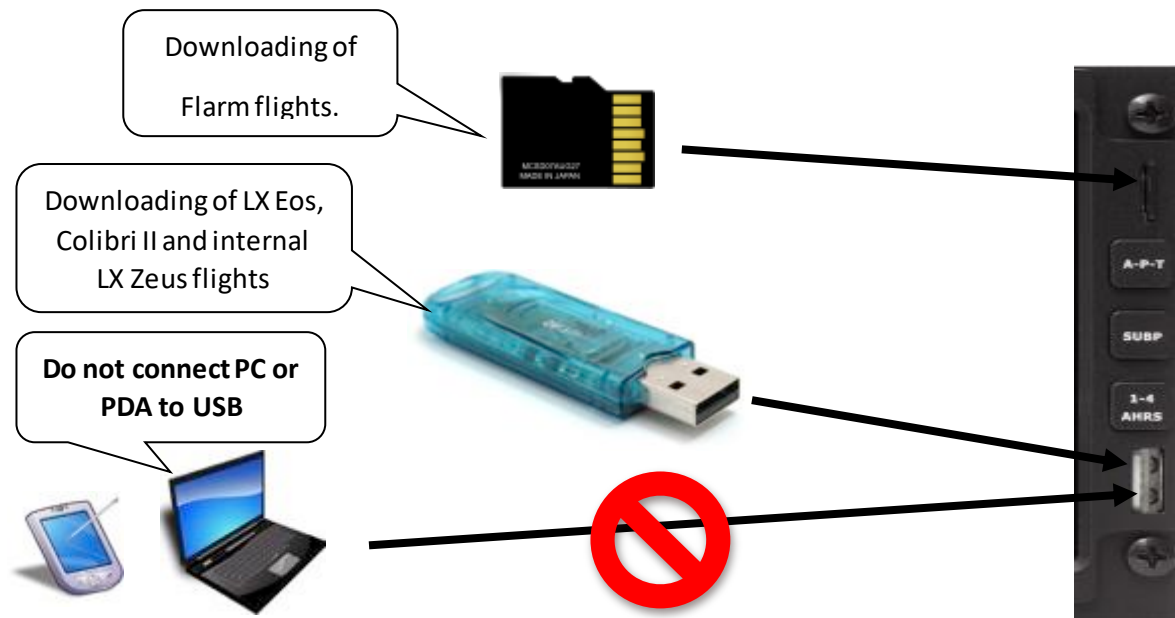

**Note!**  
Downloading flights from second seat is not possible – only from 1<sup>st</sup> seat.

### 12.3.1.1 Downloading LX Eos/Era and Colibri II flights

Once the security calculation is finished it is possible to start the flight download procedure. Downloading flights stored in LX Eos/Era or Colibri II is done using a USB stick.

In the case of LX Eos and Colibri II, the LX Eos logbook has priority. To access Colibri II logbook press the Colibri II screen button.

Download procedure:

- **Insert USB** stick
- Press **STAT** button (logbook will open)
- With Volume rotary knob **select** flight of interest
- Press **Save to USB** screen button to start downloading flight to USB

The process will take a couple of seconds or perhaps minutes depending on flight time and recording interval. When the transfer is finished a confirmation message will appear.

**Note!**

In case of troubles (error messages USB not detected, etc.), switch LX Zeus OFF, remove USB stick, switch LX Zeus ON and try again.

**Password 46486**

This password will delete all flights stored in LX Eos/Era, Colibri II and also all pilot history in ZEUS!

The flight is now available on the USB stick in the LX folder **Flights**. Flight data is stored in .IGC format and is therefore immediately ready for evaluation. The data security level meets the **IGC high level** approval standard.

### 12.3.1.2 Downloading Flarm flights

If an IGC approved LX Flarm Red Box unit is connected to LX Zeus, it is possible to download a flight directly via the SD card slot, which is positioned on the front panel of LX Zeus. The SD card slot is wired directly to the LX Flarm Red Box SD card reader without any LX Zeus interaction. The general rule with Flarm is that a flight will be stored to SD card *after next power on*. So, power LX Zeus off and on to download the latest flight. It is suggested that the SD card is kept in the LX Zeus SD slot all the time in order to avoid long waiting times from the downloading of many flights that are not yet on the SD card.

If the card is empty, then the first power ON will download ALL FLIGHTS stored in the Flarm and this will take a long time. It will download the last 20 flights stored in Flarm. Flarm will always store a maximum 20 flights, so, if a 21<sup>st</sup> flight is made, the oldest flight will be removed automatically.

### 12.3.1.3 LX Eos/Era, Colibri II – Zeus interaction after landing

After a landing is detected the LX Zeus will wait for **2 minutes** and, if during this period no movement (high GS, etc.) is detected, the procedure to close the flight will start. After the time-out (2 minutes) the unit will be ready to start the download procedure for flights stored in LX Eos/Era and Colibri II.

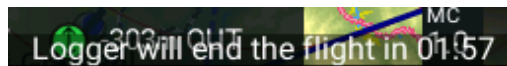

#### Recommended!

Keep LX Zeus powered on until 2 minutes have passed from the flight's finish.

#### Note!

Separate switching off of Eos/Era and/or Colibri II isn't necessary.

After the LX Zeus has powered **OFF**, Colibri II will **remain ON** for a limited time (approximately 5 minutes) and will then switch off automatically. This will not happen, though, if LX Eos/Era or Colibri II are in flight mode while running on internal battery.

#### Note!

If LX Zeus **loses power during flight** this will not switch off LX Eos/Era or Colibri II. The IGC flight recorder has an internal backup battery for such occasions.

## 12.4 ICAO charts

LX Zeus offers the use of ICAO charts from Rogersdata and Deutsche Flugsicherung. Charts can be ordered via [update-service@lxnavigation.si](mailto:update-service@lxnavigation.si). Please read **Data transfer** for the installation process.

Rotating Zoom rotary knob to the left will show ICAO charts. There are 3 zoom steps available for ICAO charts.

Zoom steps from left to right:

- Task zoom (vector map)
- ICAO zoom 1
- ICAO zoom 2
- ICAO zoom 3
- Map zoom 1:2500000
- Map zoom 1:2000000
- Map zoom 1:1000000
- Map zoom 1:500000
- Map zoom 1:250000
- Map zoom 1:125000
- Map zoom 1:62500
- Map zoom 1:30000
- Map zoom 1:15000

#### Note!

End of the chart will be shown as white background on the screen.

If the glider is located out of the chart's area the ICAO chart won't appear – vector maps will replace it.

## PART FOUR - Miscellaneous

### 13 Installation (Other components)

#### 13.1 Installation of LX Flaps sensor

The unit is capable of detecting longitudinal movement of the flap lever command rod. The device, which converts longitudinal movement into an electrical signal, is a high-quality wire-wound multi-turn potentiometer. A spring based self-retracting system returns the cord in case of backward movement of the flap lever rod. The high-quality cord allows control rod movement of up to 300 mm, which enables the unit to be used for all gliders currently available. For installation purposes, only two wires are used to connect the electronic device LX CanAD, which converts resistance data into digital signal. The electronic device is a part of the CAN system bus.

For complete mechanical installation see the LX Flaps sensor manual, for sensor calibration see chapter Flaps sensor calibration.

#### 13.2 Electrical installation

##### 13.2.1 LX Zeus with Vario (USB-D 60)

This part of the installation is easy and doesn't require any specialists. The system receives its power via two power lines, which should be connected to 12V glider power source and ground. The red wire is 12V and blue wire is Ground.

#### **Important!**

There is no **fuse** built into the system, it is obligatory to fit a 3A external fuse. **Never remove the CAN BUS Terminator**, which occupies one CAN port (factory pre-set). A terminator should only be removed for second seat configuration. **In that case the terminator should be positioned on second seat unit.**

A 2-pole plastic power connector, which is positioned approximately 20 cm from the unit casing ensures simple disassembling of the unit in case of repair.

### 13.2.1.1 Installation of USB-D 60 (Vario unit)

The USB D 60 unit comes with prefabricated cable set, which has two connectors. The 15-pole type should be inserted into the vario unit and should be secured with the appropriate spring locks. The 9P connector should be inserted into any free 485-marked plug on LX Zeus back. The unit receives power from LX Zeus. Speaker output is terminated with one chinch female connector. A male chinch connector is part of the speaker delivery.

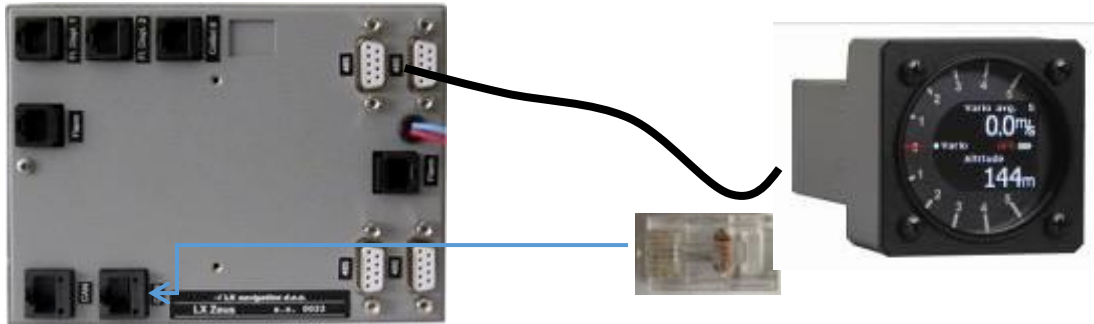

A CAN terminator can be inserted either into the left or right CAN PORT. It is not important which is used.

9P (485 system bus) can be connected also to any free 485-connector plug.

13.2.1.2 USB-D 60 wiring

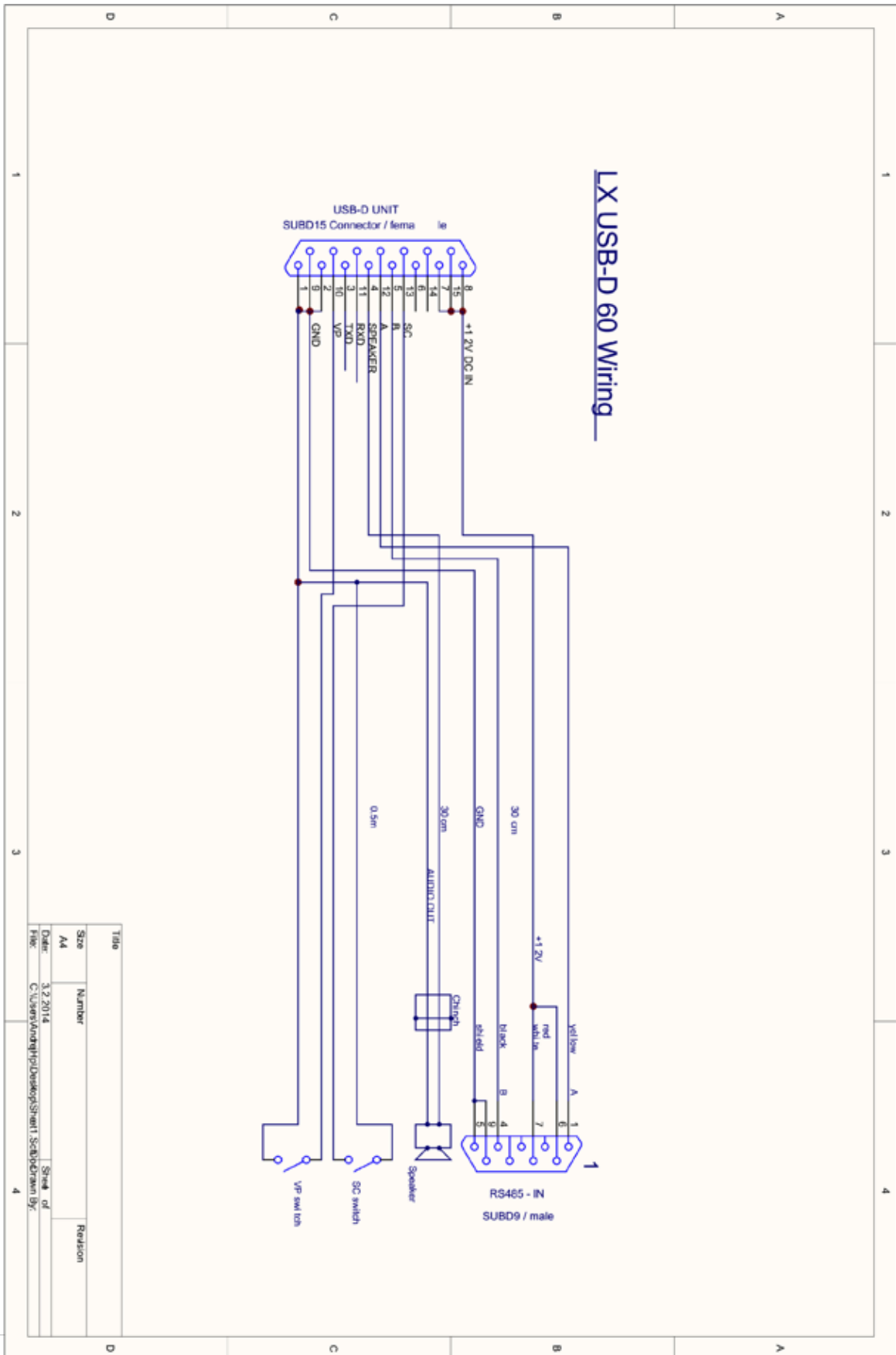

Title		Revision	
Size	Number	Size	Number
A4			
Date:	3.2.2014	Sheet of	
File:	C:\users\andyp\Documents\Stewart_Schubert\lxc	of	

### 13.3 Installation of second seat units

The second seat unit shares the same logic as the master LX Zeus. There is no difference in mechanical installation.

#### 13.3.1 Electrical installation

The second seat unit doesn't need external power as it is powered via the system bus (CAN). For CAN connection two 8P connectors are provided on both the master and the repeater. The connection of both units is simple and easy, all that is necessary is to insert CAN marked cable into one of two CAN marked plugs. The same is valid for first and for second seat. The second seat unit comes with two red wires which are terminated with a toggle switch. It is recommended that this switch is installed somewhere on the rear panel, as this will make it possible to switch off the second seat unit during single pilot operation in order to reduce power consumption.



**Note!**

Never remove CAN terminator which occupies one CAN plug of the second seat unit if Vario is connected. If LX Zeus is connected to LX Eos/Era, you should remove terminator!

**Note!**

Older vario units, which operate via 485 bus and that are to be used on the second seat, should also be connected to the second seat 485 bus:

- LX Remote Stick
- Vario indicators

A Compass module or Voice module should be connected only to first seat. All CAN devices can be connected to first or second seat.

## 14 [Explanation of NavBox terms](#)

Item	Description	NAV BOX designator
Above ground level	Altitude above ground level	AGL
Air temperature	OAT	Temp
Altitude IGC	Altitude recorded by flight recorder (1013 based)	Alt IGC
Altitude GPS	Altitude recorded by GPS	GPS Alt
Altitude QFE	QFE altitude based on zero altitude at known position	Alt QFE
Altitude QNH	Altitude above sea level	Alt QNH
Altitude QNH (ft)	Altitude above sea level in ft	Alt QNH
Analogue clock	Analogue clock symbol	Clock symbol
Arrival altitude	AGL height (+reserve) on arrival at selected TP	Arri Alt
Average vario	Integrator (average of last x seconds – set in SETUP / VARIO SC / Integration scale)	V Avg
Average netto vario	Average of air mass vertical movement during the whole flight	AVG netto
Battery	Battery symbol	Battery symbol
Bearing TP/APT/T	Bearing to TP/APT or TP of task	BRG
Circling radius	The radius of circling in a thermal	Circ Rad
Compass heading	Heading that is calculated from compass (if compass module is installed)	HDG
Cur. eff. TP/APT/TSK	Efficiency calculated during last time period	E
Compass Heading		HDG
Digital clock	Digital clock symbol	Time
Distance in NM to sel. TP/APT	Distance to TP/APT in NM	Dist NM
Dist. to sel. TP/APT	Distance to TP/APT	Dist
Empty	NAV BOX will remain empty	No designator
ETA (average speed)	ETA based on average speed reached	ETA Avg



ETA (current speed)	Estimated time of arrival based on actual speed	ETA Sp
ETA MacCready speed	ETA based on MC setting	ETA MC
Final glide	Altitude difference related to f.g. line	FG
Final glide (MC0.0)	Altitude difference related to f.g. line at MC 0.0	FG(MC 0.0)
Flight level	Actual flight level indication	FL
Flying time	Time spent in the air	Flying
GPS position	Indication of coordinates	Coordinates
GPS signal	GPS status symbol	GPS Symbol
Ground speed	Speed over ground	GS
G-force	Current G-force in glider	G-force
Horizontal distance from airspace	Glider position horizontally from the airspace	AS hor
Indicated Air Speed	Airspeed not altitude corrected	IAS
Leg speed	Leg speed on task	Leg speed
Netto vario	Shows air mass vertical movement	V Netto
Off course distance	Off course indicator	Off co
OLC	OLC point scored to current location	OLC
OLC home	OLC points that will be scored if takeoff position is reached.	OLC Home
OLC speed	Speed when flying a cross country flight under the rules of OLC	OLC sp
Optimal speed to fly	Required speed to fly based on current MC settings	STF
Radial TP/APT	Radial from TP/APT to the glider position	QDR
Recommended flaps position	Recommended flaps at pre-set speed range	Flaps
Relative vario	Netto vario – 0.7	V relative
ETE – estimated time enroute	Remaining time to selected TP/APT or until end of TSK	ETE
	Required efficiency to reach TP/APT/TSK	Req E

Required eff. TP/APT/TSK		
Required speed	Required speed to finish AAT in time	Req Sp
Required MC	Required MC to reach TP/APT, finish TSK	Req MC
Set MacCready	Actual MC setting	MC
Sink Speed	Estimated sink rate (polar, speed, bugs, MC)	Sink Sp
Task delta time	Early or late arrival at task finish	TDT
Task remaining distance	Distance to go until finish	Task RD
Task speed	Speed achieved on task	Task Sp
Team Bearing	Bearing of your team partner	Team BRG
Team Code	Coded location of your team partner	Team code
Team Distance	Distance to your team partner	Team Dist
Thermal all	Altitude gain during whole flight	Th All
Thermal average	Average climbing during last whole thermal (usable for MC setting)	Th Avg
Thermal gain	Altitude gained during last climb	Th Gain
Thermal last 30	Altitude gain during last 30 seconds of climbing	Th L30
Time on leg	Time spent on leg	On Leg
Time on task	Time spent on task	On Task
Time to go	Time until the end of TSK	TTG
Track TP/APT/TSK	Ground track to TP/APT or TP of task	TRK
True Air Speed	Airspeed corrected with altitude	TAS
Vario	Momentary variometer value	Vario
Vertical distance from airspace	Glider position vertically from the airspace	AS ver
Wind direction	Wind direction calculated by Zeus	Wind Dir
Wind speed	Wind speed calculated by Zeus	Wind Sp

## 15 [FAQ \(frequently asked questions\)](#)

### 1. **Can I connect Swiss Flarm and how will it work?**

Flarm can be connected to LX Zeus NMEA (flarm) port. Zeus will see flarm objects and will send declaration to flarm (task and pilot's settings)

### 2. **Volkslogger, Colibri and other loggers - how to connect and what is the advantage?**

Loggers can be connected to NMEA (flarm) port. Zeus will take GPS signal from them and give them 12 V power.

### 3. **What do I get if I buy LX ZEUS FLARM IGC**

LX Zeus Computer, Flarm IGC logger, Flarm dipole antenna, SD card for Flarm, Flarm cable to Zeus, Flarm SD cable to Zeus, Flarm GPS antenna, LX Eos IGC, main power cable with switch, SD card reader, SD card (micro), SD to micro adapter, input interface, speaker, GPS antenna, OAT sensor with cable, CAN cable, IGC cable for Oudie, baro trace, USB key  
For more information, please check with your local dealer.

### 4. **Zeus shows Voltage .0.0 V?**

Voltage is measured on the Vario unit, so this means that there is a problem with connection ZEUS – Vario. Check connection – cable and both units.

### 5. **Voltage – what is the operating Voltage?**

LX Zeus operates approximately from 8 V to 16 V.

### 6. **ADSB and Powerflarm on Zeus – how to connect, what kind of warnings, warnings with Voice modules?**

ADSB can be connected direct to LX ZEUS using the FLARM port. Zeus will provide all Flarm warnings – same as Flarm Red Box or Mini Box.

### 7. **LOUDIE – is it possible to connect, what cable, where to connect?**

Oudie can be connected either via a special Power and data cable, which is provided with each Zeus, or by connecting it via Bluetooth to LX Eos/Era varios.

### 8. **AIRSPACE Warnings and a Voice module?**

The voice module will also give voice-warnings for airspaces.

### 9. **ENL and Zeus?**

If an IGC Zeus is ordered, then the ENL sensor is the part of the system without charge (built in Colibri II, LX Eos)

### 10. **AHRS – is it adjustable so that it can be set on the ground?**

Yes, of course. For explanation of the procedure, check the relevant chapter in this manual.

### 11. **CONDOR simulator – can you connect Zeus and play with it?**

Not possible by default (must be specified when ordering). There will be only GPS data, no baro data.

### 12. **Can I use OAT sensor from LX 7007, LX 7007 C and LX 5000?**

It is not possible.

### 13. **Can I use remote from LX 5000, LX 7007 / C?**

The Remote Stick can be used from LX5000 (not valid for keyboard type), 7000, 7007 and 7007 C. Only the button-descriptions have changed with the new Zeus functions. The rubber top can be changed to modify the buttons; this can be done by the user.

**14. Why does LX Zeus restart when I switch from battery 1 to battery 2?**

You are probably using the wrong switch. You must not use a switch, which cuts off power for a short period when you change from battery 1 to battery 2. You should use a switch that always lets the current through to Zeus.

**15. How to do a system reset (completely delete the software and install it again)**

- Push on zoom rotary switch,
- Go to setup,
- Go to Admin password
- Enter password: 49046 and push on zoom rotary switch (this will delete the software)
- To install the software do as is instructed in chapter 3 Update procedure.

**16. I am having problems with the communication between the primary Unit and the secondary Unit on my double seater, what can I do?**

First check that the Zeus units are connected. This is done by a long press on Setup/info button. In the Info window, there should be a sign either primary unit or secondary unit.

If there is no sign do a system reset on the secondary unit as is explained on the previous answer. When the installation of the software is done, a message will appear, asking you if this is the primary or secondary unit. Select secondary unit.

**17. Cyclic restarts of Zeus.**

Zeus detects cyclic restarts and advises users to reset the system. If a user chooses to do a reset the Zeus will back-up the important user files on a USB key, if one is inserted in the unit.

Resetting the system might help to remove the restarting problems, if this does not work, contact your LX Navigation dealer.



**LX**  
navigation

The image features a solid blue background with a network of white lines and circles at the top and bottom. The circles vary in size, and the lines connect them in a complex, web-like pattern. In the center, the text 'LX' is written in a large, bold, white sans-serif font, with 'navigation' in a smaller, lowercase white sans-serif font directly below it.